

CONVAULT[®] OWNER'S MANUAL

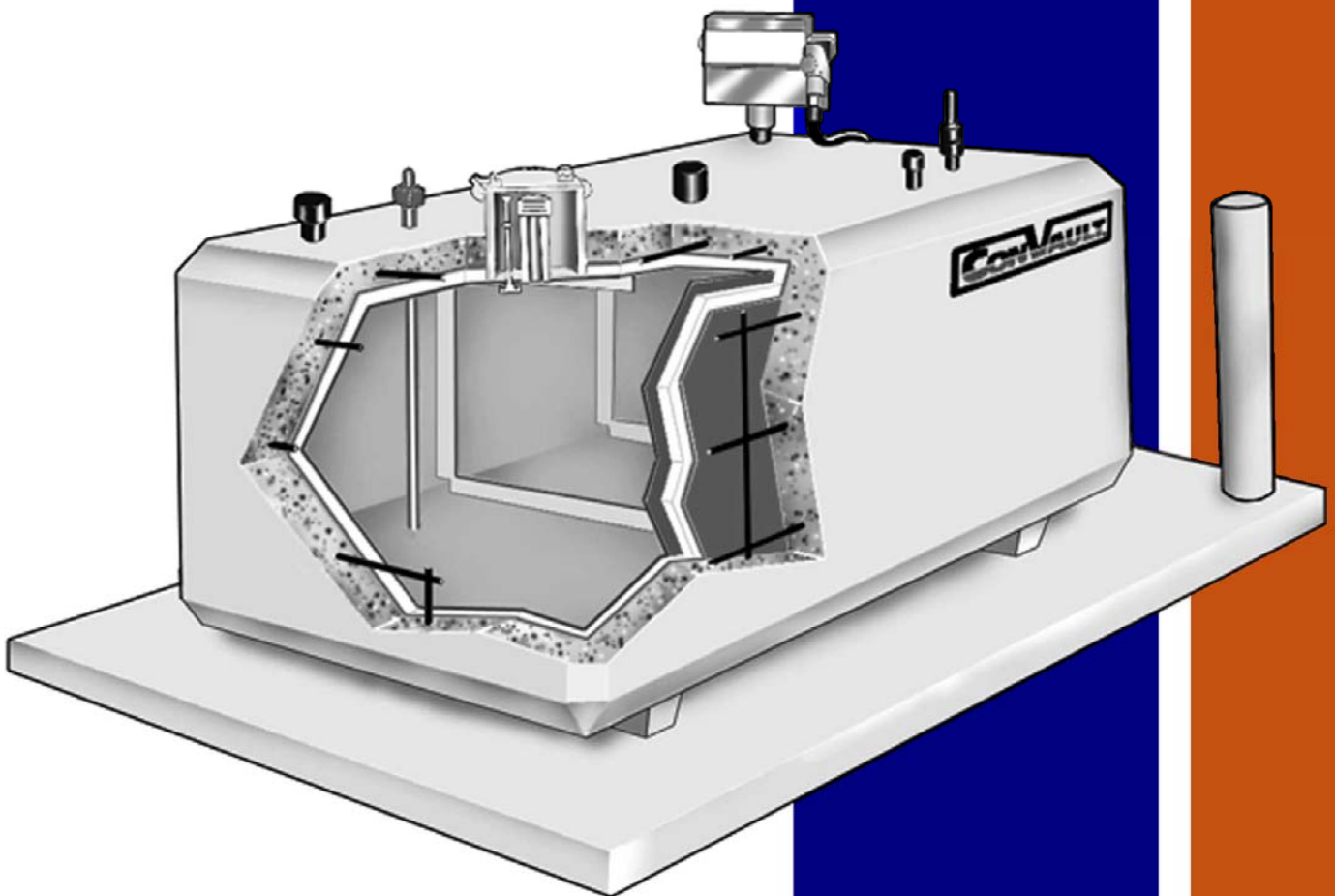



OWNER'S MANUAL TABLE OF CONTENTS

	Page No.
CONGRATULATIONS NOTE	1
SAFETY ALERT SYMBOL & WORD SIGNS	2
PRODUCT DESCRIPTION	3-18
LIMITED WARRANTY	19-20
INSTALLATION INSTRUCTIONS	21-41
OPERATING MANUAL	42-49
MAINTENANCE MANUAL	50-56
TESTING MANUAL	57-61
APPENDIX A- MAINTENANCE CHECKLIST	A1-A3
APPENDIX B- LIGHTNING PROTECTION	B1

An electronic version of the owner's manual and other documents are available upon request and online.

**** SAVE THIS OWNER'S MANUAL ****

© October 1995 by ConVault, Inc. All rights reserved.



CONGRATULATIONS

You have purchased a state-of-the-art aboveground fuel storage tank. ConVault® tanks will give you many years of satisfactory and useful life. ConVault's® complete aboveground vaulted tank and fueling system is a practical and inexpensive alternative for storing petroleum products and other flammable and hazardous substances. Constructed of steel and housed in an attractive concrete vault, the protected secondary containment tank is a cost-effective way to meet your fuel storage needs.

You will be pleased to know that ConVault® is the storage tank of choice for all levels of government and many national corporations. Over 30,000 ConVault® Aboveground Storage Tanks (AST) have been installed worldwide in the last nineteen years.

We are interested in your comments and suggestions. Contact the corporate office:

By mail: ConVault®, Inc.
4109 E. Zeering Road
Denair, CA 95316

By phone: 800-222-7099

By fax: 209-632-4711

By e-mail: info@convault.com

By Internet: Visit our web site at <http://www.convault.com>.

SAFETY ALERT SYMBOLS AND SIGNAL WORDS

Throughout this Owner's Manual, we have used safety alert symbols and different signal words to alert you to potential personal injury hazards and damage to the property. Obey all safety messages that follow the safety symbol and signals. Below, we have explained the meaning of the safety alert symbol and signal word.



DANGER indicates an imminently hazardous situation, which if not avoided, will result in death or serious injury.



WARNING indicates a potentially hazardous situation, which if not avoided, could result in death or serious injury.



CAUTION indicates a potentially hazardous situation, which if not avoided, may result in minor or moderate injury.



CAUTION used without the safety alert symbol indicates a potentially hazardous situation, which if not avoided, may result in property damage.

PRODUCT DESCRIPTION

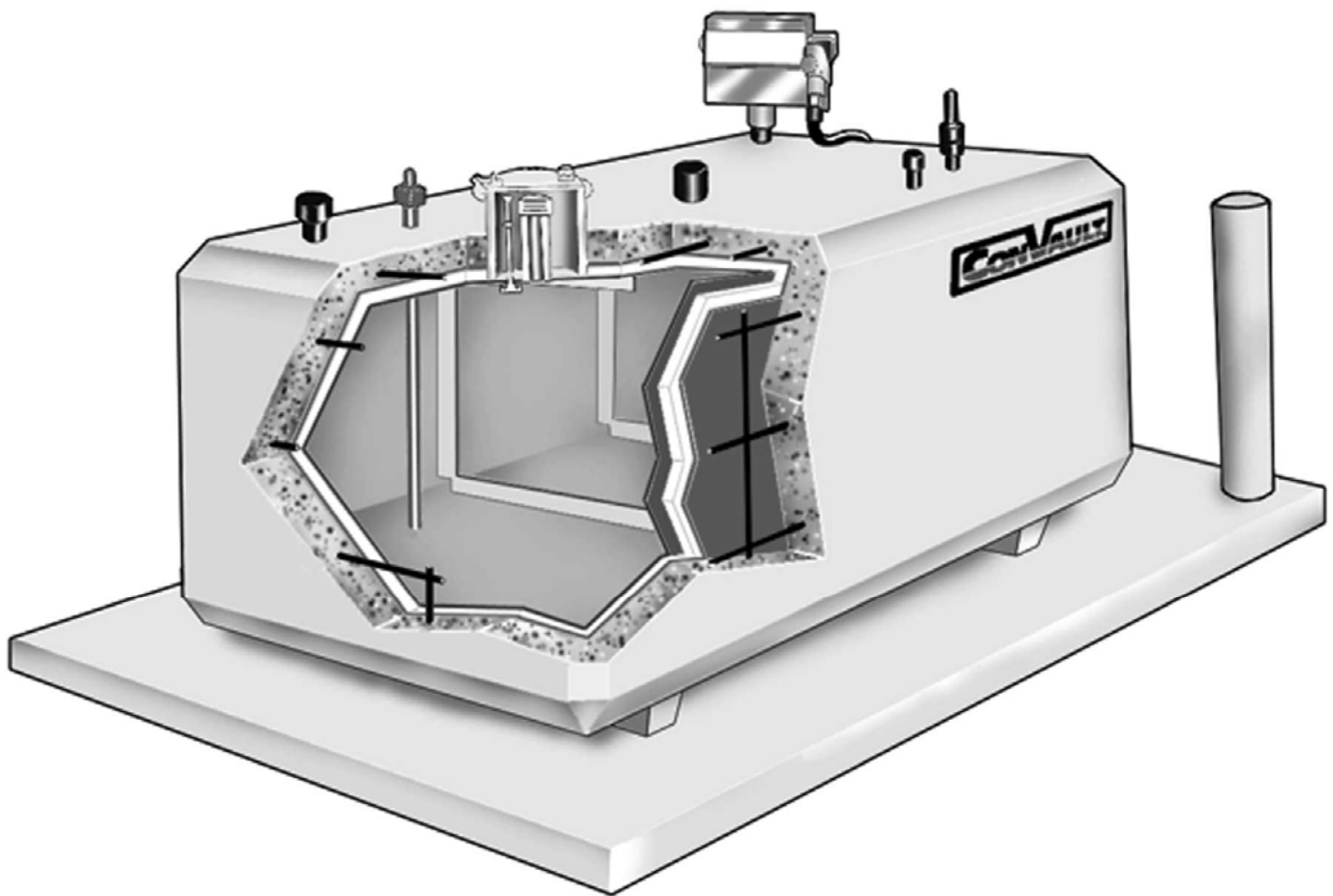



TABLE OF CONTENTS

	Page No.
A. THE BACKGROUND	5
B. ENGINEERED FOR SAFETY	6
C. THE MANUFACTURING PROCESS	8
1. The Steel Tank Construction	8
2. Secondary Containment	8
3. The Concrete Vault	9
4. Coating and Finishing	9
D. ADDITIONAL FEATURES	9
1. Complying with Environmental and Fire Safety Requirements	9
2. UL/ULC Listed	10
3. Overfill Protection	11
4. Venting	11
5. Support Legs	11
6. Thermal and Corrosion Protection	11
7. Spill Containment	11
8. Vehicle Impact Resistance	12
9. Bullet Resistance	12
10. Non-Metallic Secondary Containment	12
E. TANK WEIGHTS AND DIMENSIONS	12
F. PERMITS AND APPROVALS	17



PRODUCT DESCRIPTION

A. The Background

- 1.** You are probably aware that underground fuel storage tanks are a main source of soil contamination in this country. Underground fuel storage tanks corrode, leak fuel oil and gas into the soil and cause soil contamination. The contaminants may reach the underground water streams and could be carried into the drinking water systems. Decontamination of the underground fuel storage tank's location is extremely costly and can have a devastating financial burden on tank's owners and operators.
- 2.** Regulatory agencies have enacted many guidelines requiring the owners and operators of the underground fuel storage tanks to install expensive leak detection and monitoring facilities to prevent costly contamination problems.
- 3.** There are also many regulations covering installation and operation of "non-protected" aboveground steel storage tanks.

To solve the problems associated with the underground storage tanks and the non-protected aboveground steel storage tanks, ConVault® developed a breakthrough idea of constructing a tank that does not have the costly underground tank's leak monitoring system and contamination problem and at the same time has overcome the problems associated with the unprotected aboveground steel tanks. Because of its unique monolithic concrete construction features, the ConVault® tank system provides two (2) hour fire protection, vehicle impact resistance and ballistic resistance proven by the tests carried out by the Underwriters Laboratories of USA (UL) and Canada (ULC).



B. Engineered for Safety

1. The design and manufacturing concept of the Convault® is simple and at the same time very practical. In a nut-shell, Convault's® design concept consists of:
 - a) Constructing a welded steel tank to store and contain flammable and combustible liquid fuels.
 - b) Insulating the steel tank exterior by a minimum of 1/4" thick Styrofoam and wrapping it in a 30 Mil high-density polyethylene membrane to provide a secondary containment for the remote possibility of a fuel leak through the steel tank.
 - c) Encasing both the poly and the steel tank in 6" thick monolithic reinforced concrete vault to provide two-hour fire protection, ballistic and vehicle impact protection.
2. Convault® has even designed a simple leak detection system that enables checking the tank for leaks on a regular basis. Using a stick, the operator can easily check the leak detector chamber for liquid. A dry leak detector chamber indicates no leak. Mechanical or electronic monitoring systems can also be used to monitor the tank for potential leaks.
3. Convault® is so confident of its superior design that it gives 20 to 30 years of warranty for its steel tanks. Provided that the tank is installed, operated, maintained and tested in accordance with Convault's® specifications, Convault® will replace your tank without charge if it develops a leak. See your standard warranty for its actual number of years and its conditions.

Since you have purchased one of over 30,000 tanks, which remain in service since 1987, you may wish to understand the unique manufacturing process of Convault® tanks. The following paragraphs will explain the construction process of the Convault® tanks.

Figure No. 1

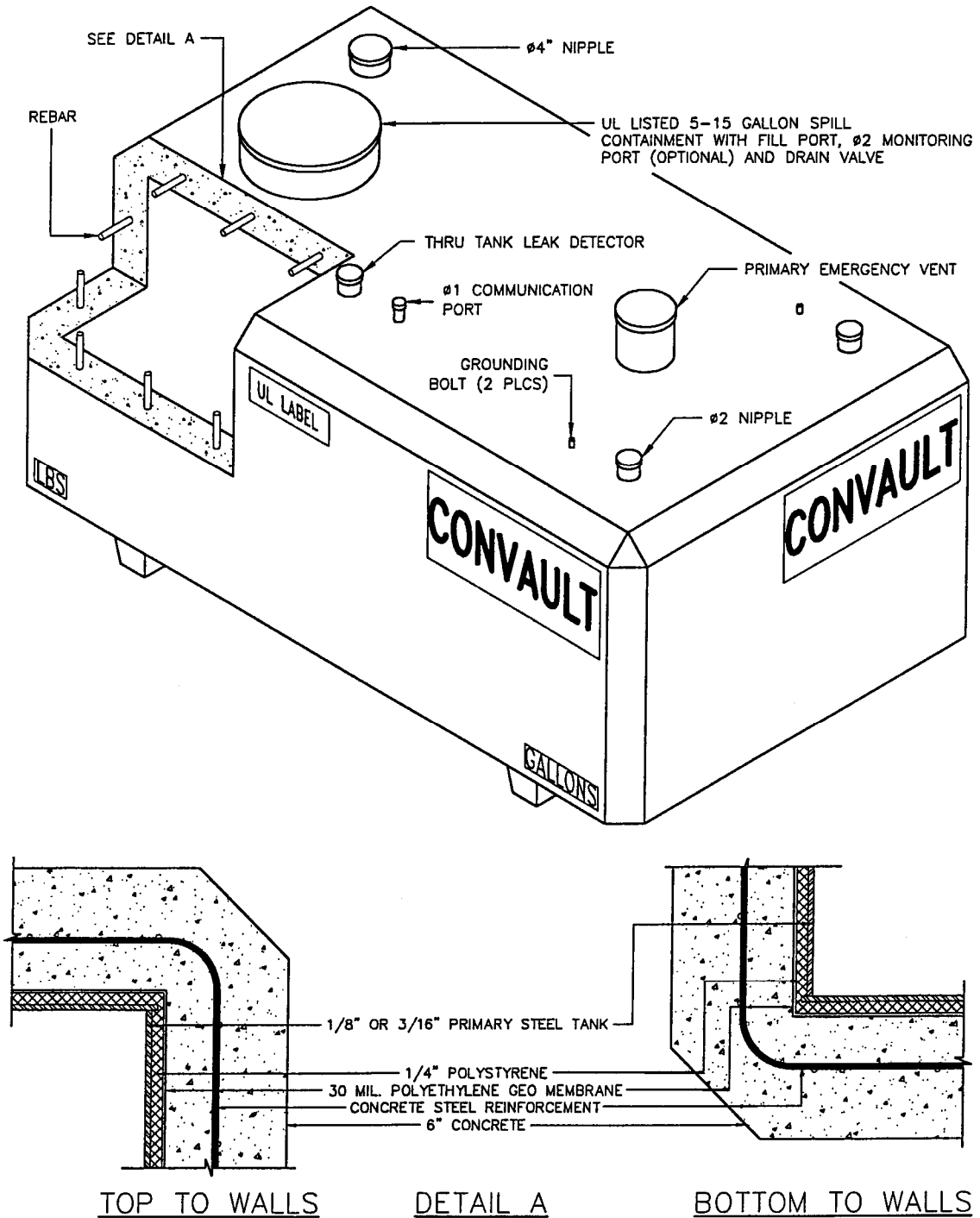

C. The Manufacturing Process

Convault® tank construction process consists of four main steps, namely:

1. Steel Tank Construction
2. Secondary Containment
3. Concrete Vault
4. Coating and Finishing

Figure No. 1, page 7 is an isometric view of a typical Convault® tank with a cutaway section to show details of a Convault® tank system. The four main manufacturing steps are further described below:

1. Steel Tank Construction

- a. Convault® steel tanks are made of 1/8", 3/16" or 1/4" thick steel, depending on warranty and tank size. The steel tank contains and holds the liquid fuel, which is the primary function of the tank. To make the steel tank systems fit for their function; the steel tanks are made in accordance with the UL standard 142 and ULC standard S601. The UL/ULC standards cover all the aspects of tank fabrication including material specification, fabrication, welding and testing. The tanks are listed in accordance with UL/cUL Standards and carry UL/ cUL labels as such.
- b. At the fabrication shop, the tanks undergo a number of quality control and test procedures including a 24 to 48 hour pressure test at five (5) psig.

2. Secondary Containment

- a. The second stage of manufacturing consists of wrapping the steel tank with a minimum of 1/4" thick Styrofoam (foam) insulation and an impervious barrier of 30-Mil high-density polyethylene membrane (poly). The 30-Mil poly provides containment for the remote possibility of a fuel leak through the steel tank. A leak detector pipe terminating in the secondary containment provides a positive-proof that the tank is not leaking.
- b. Another advantage of the 30-Mil poly is that it shields and protects the steel tank exterior from coming in direct contact with concrete and thus minimizes the potential risk of tank external corrosion.

- c. Certain Authorities Having Jurisdiction require metallic secondary containment. Convault® manufactures double wall steel tanks to meet the above requirements. The secondary steel containment is wrapped in 30-Mil poly to prevent external corrosion. In effect this tank system provides triple containment; namely, primary steel tank, the secondary steel tank and tertiary 30 Mil poly.

3. The Concrete Vault

The next step of manufacturing a Convault® tank is to encase the tank in a six (6) inch thick reinforced concrete vault. Simply put, the six (6) inches of concrete is poured on all sides bottom and top of the tank in one step and hence the phrase “monolithic”. This process assures that there are no joints and no heat sinks in the concrete to carry heat from a fire into the primary containment. The combination of the 30 mil poly and six (6) inch concrete provides a protected secondary containment system.

The concrete pouring process also goes through a strenuous quality control procedure to make sure the Convault® tank withstands all performance tests; namely the two (2) hour fire test, the vehicle impact resistance test and ballistic impact resistant test. Convault® tanks are listed by UL 2085 Standard and ULC S655 (ULC/ORD 142.16) Standards as fire resistant, insulated and protected tanks.

4. Coating and Finishing

At the final stages of manufacturing, the concrete exterior of the tank is vacuum coated using a two-part water based epoxy paint to protect the tanks from the inclement weather conditions. Concrete exterior can also be produced in exposed aggregate with a clear coat of sealant, in STO finish or in Perma Crete finish. All nipples protruding from the tank are powder-coated to protect them from corrosion.

D. Additional features

The following is a list of some of the major features and advantages of Convault® tanks:

1. Complying with Environmental and Fire Safety Requirements

- a) Convault® tanks meet applicable safety requirements for secondary containment, leak monitoring, and spill protection. Convault® tanks are approved by regulators and fire officials in most local jurisdictions of the United States and many foreign countries. Convault® tanks are installed in 26 different countries worldwide.



- b) Convault® tanks meet NFPA 30, NFPA 30A, UFC, BOCA, SBCCI, and IFC model fire codes safety standards. The units also comply with the 1996 Uniform Fire Code (UFC) Appendix A-II-F for the aboveground storage and dispensing of motor fuels.
- c) Convault® tanks are certified by the California Air Resources Board for Balanced Phase 1 and Phase 2 Vapor Recovery including methanol and ethanol.

2. UL/ULC Listed

The Convault® tanks have been tested and have passed all requirements of the following UL and ULC Standards:

- a) **UL - 142, aboveground tanks for flammable and combustible liquids.**
- b) **UL - 2085, two-hour furnace fire test and two hour simulated pool fire test for insulated fire resistant and protected tank.**
- c) **UL - 2085, insulated and protected secondary containment aboveground tanks for flammable and combustible liquids.**
- d) **UL - 2085 and UFC SECTION (79-7) vehicle impact and ballistic impact test for protected tank.**
- e) **UL – 2085/ULC S655 (CAN ORD-C 142.16) Non-Metallic Secondary Containment and Venting by Form-of-Construction.**
- f) **UL – Standard 2244 Systems Listing for Motor Vehicle Fuel Dispensing.**
- g) **UL CAN/ORD - C 142.16, protected aboveground tank assemblies for flammable and combustible liquids.**
- h) **UL CAN/ORD - C 142.5, concrete encased aboveground tank assemblies for flammable and combustible liquids.**
- i) **UL CAN/ORD - 142.16, the furnace burn and 142.5, the open (pool) fire testing for two-hour fire rating.**



3. Overfill Protection

Tanks can be provided with the following methods to protect them against overfill:

- (a) direct reading level gauge at the tank which is visible from fill pipe location;
- (b) valve located within fill-pipe access to close or restrict flow automatically at a specified fill level;
- (c) audible high level alarm activated by a float switch at a specified fill level.

4. Venting

The Convault® tank systems are furnished with a 2 inch normal vent and an emergency pressure relief system. The emergency relief system furnished with the tank normally opens if the tank pressure exceeds 1/2 psig. The tank systems conform to the national model fire codes and UL/ULC Standards for venting.

Convault® secondary containment is listed by UL/ULC for “Venting by Form of Construction” and therefore is not required to be equipped with emergency venting device for secondary containment.

5. Support Legs

Vaults have concrete support legs of unitized monolithic construction that provide visual inspection capability. Tanks do not require cathodic protection system as no steel part of the tanks comes in direct contact with the ground.

6. Thermal and Corrosion Protection

The tank construction includes thermal insulation to protect against temperature extremes and corrosion by separating the steel tank from the concrete. No part of the steel tank comes in direct contact with concrete or other corrosive materials. All nipples, manway and spill container are powder coated for protection against corrosive elements.

7. Spill Containment

The tank system includes a 5 to 15 gallon, powder-coated UL-Listed and patented, spill containment surrounding the fill pipe. The spill container is equipped with a normally closed hand operated valve that can be actuated to drain the spilled fuel liquids into the primary steel tank.



8. Vehicle Impact Resistance

Convault® tanks are designed to have a low center of gravity that can withstand vehicle impact and tipping during earthquakes and other natural disasters. Convault® tanks have withstood even phenomenal tests such as C-130 aircraft impact at Dobbins AFB in Georgia, Hurricane Andrew and the 1989 Loma Prieta earthquake.

9. Ballistic Resistance

Convault® tanks withstand bullet resistance tests in compliance with UFC SECTION (79-7) APPENDIX # A-II-F-1 and UL 2085 Standard for Protected tanks.

10. Non-Metallic Secondary Containment

The UL 2085 Standard listing officially recognizes Convault® tank of having a secondary containment. Technically, this is equivalent to a protected and insulated double wall steel tank. Therefore, the Convault® tank provides you a secondary containment equivalent to a double wall steel tank plus protection of six-inch reinforced concrete.

- **NOTICE: UL Standard 2085 requires Aboveground Storage Tanks (AST) to be evaluated to determine acceptability for continued use after fire exposure, physical damage, or misuse.**

E. Tanks' Weights and Dimensions

Figures No. 2, 3, 4 and 5 give nominal capacities, the outside dimensions, general fittings layout and approximate weights of some popular Convault® systems. These are representative sizes, dimensions and weights only. While all sizes and shapes listed are available, they may not be available from your local plant. Also, most plants have additional size and dimension options that are not listed here. To prevent installation problems, and to optimize your fuel storage site, please check with your local Convault® representative before specifying or beginning site development plans. More accurate tank weights can also be obtained from your local Convault® representative to help you in arranging proper equipment for the safe unloading and setting of tanks.

Figure No. 2
Tank Weights and Dimensions *
Single Primary Tank

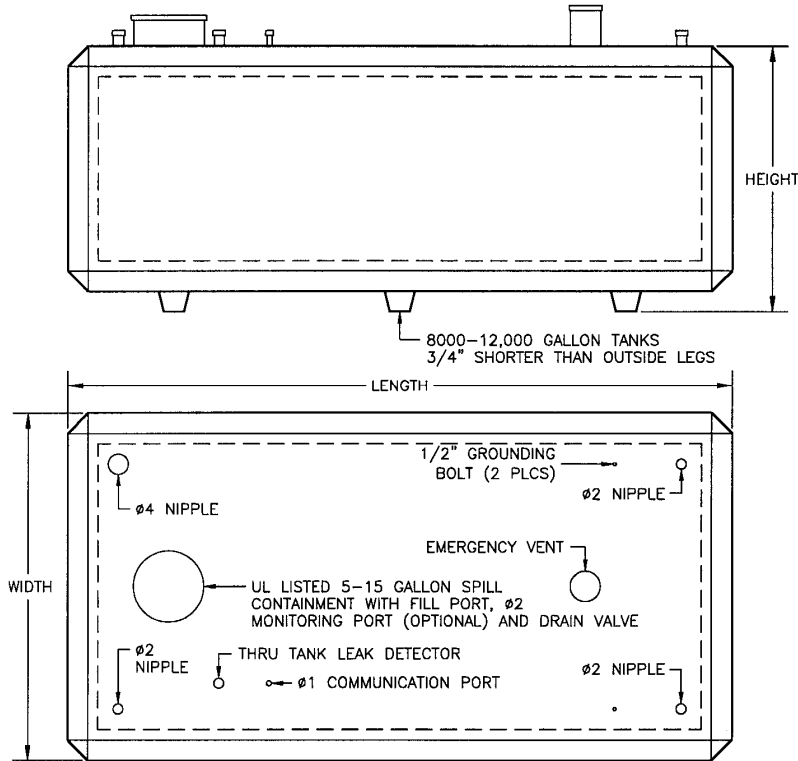

SIZE	LENGTH	WIDTH	HEIGHT	WEIGHT
125	4' - 1"	4' - 1"	3' - 11"	6,000
250	7' - 8"	3' - 9"	3' - 3"	8,000
500	11' - 0"	4' - 6"	3' - 4"	12,000
1000	11' - 0"	5' - 8"	4' - 4"	18,000
2000	11' - 3"	8' - 0"	5' - 6"	30,000
3000 LP (Low Profile)	11' - 3"	8' - 0"	7' - 3"	35,500
4000 LP (Low Profile)	17' - 7"	8' - 0"	6' - 5"	45,000
4000 DW	12' - 2"	8' - 0"	8' - 9"	40,000
5200 G (General)	15' - 6"	8' - 0"	8' - 9"	47,000
6000	17' - 7"	8' - 0"	8' - 9"	59,000
8000	23' - 1"	8' - 0"	8' - 9"	72,000
10000	28' - 7"	8' - 0"	8' - 9"	87,500
12000	34' - 1"	8' - 0"	8' - 9"	101,000

- The above sizes are typical, however some plants may not offer all tank sizes listed above. For additional sizes, or specific needs in your area, refer to your Convault® distributor/salesman.
 - Double-wall steel tanks are optional and external dimensions are identical to single wall tank.
 - Nipple layout and designs vary according to customer needs.
- * **NOTE:** These are nominal weights of the tanks. Check with your distributor/salesperson for accurate weights.

Figure No. 3
Multi-Compartment Tank Weights and Dimensions *
The “D” Design

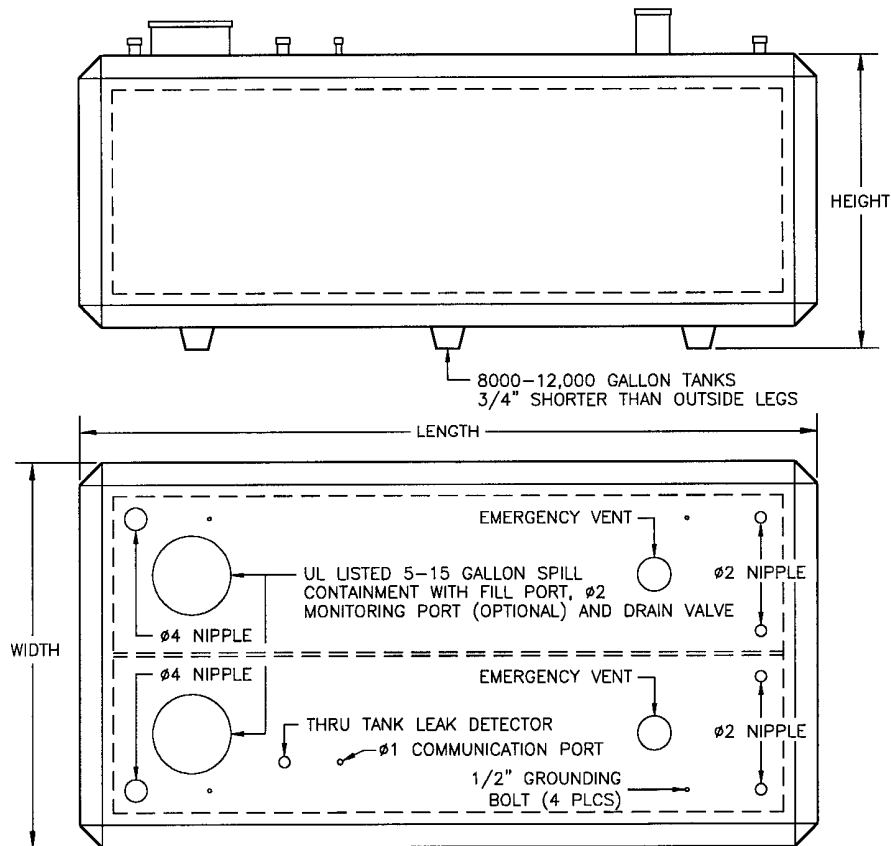

SIZE	LENGTH	WIDTH	HEIGHT	WEIGHT
D250	11' - 0"	4' - 6"	3' - 4"	12,000
D500	11' - 0"	5' - 8"	4' - 4"	18,000
D1000	11' - 3"	8' - 0"	5' - 6"	30,000
D1500 LP (Low Profile)	11' - 3"	8' - 0"	7' - 3"	35,500
D2000 LP (Low Profile)	17' - 7"	8' - 0"	6' - 5"	45,000
D2000 DW	12' - 2"	8' - 0"	8' - 9"	40,000
D2,600 G (General)	15' - 6"	8' - 0"	8' - 9"	47,000
D3000	17' - 7"	8' - 0"	8' - 9"	59,000
D4000	23' - 1"	8' - 0"	8' - 9"	72,000
D5000	28' - 7"	8' - 0"	8' - 9"	87,500
D6000	34' - 1"	8' - 0"	8' - 9"	101,000

- The above sizes are typical, however some plants may not offer all tank sizes listed above. Other multi-compartment combinations are also available. For additional sizes, or specific application needs, please contact your Convault® distributor/salesman.
- Nipple layout and design vary according to customer needs.
- * **NOTE:** These are nominal weights of the tanks. Check with your distributor/salesperson for accurate weights.

Figure No. 4
Multi-Compartment Tank Weights and Dimensions *
The “E” Design

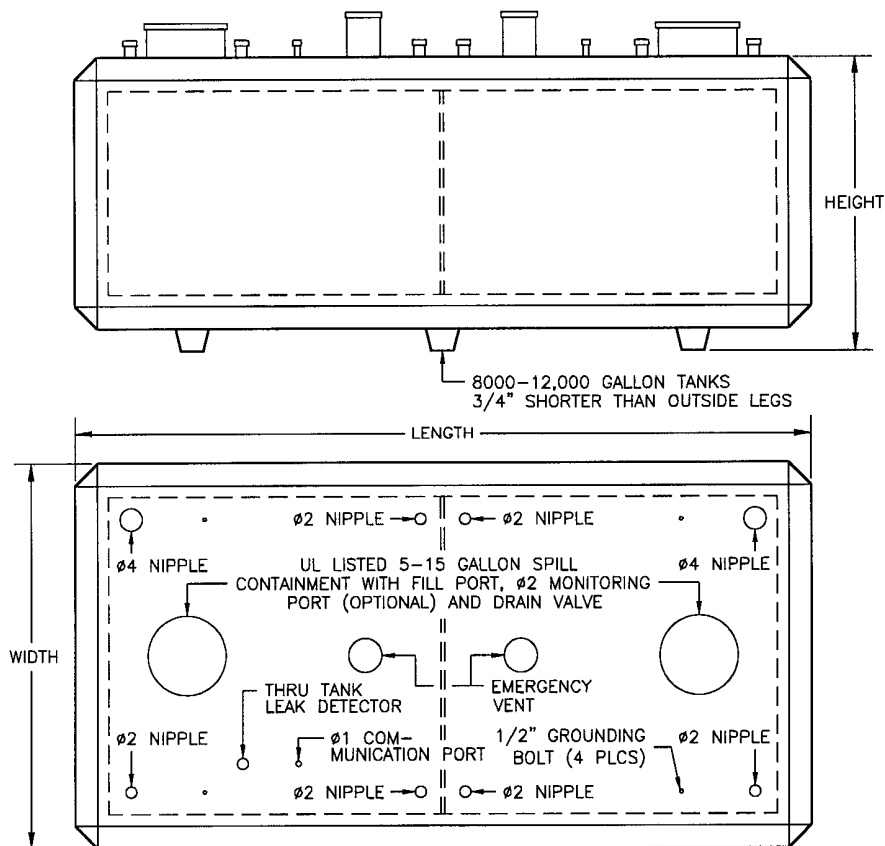

SIZE	LENGTH	WIDTH	HEIGHT	WEIGHT
E250	11' - 0"	4' - 6"	3' - 4"	12,000
E500	11' - 0"	5' - 8"	4' - 4"	18,000
E1000	11' - 3"	8' - 0"	5' - 6"	30,000
E1500 LP (Low Profile)	11' - 3"	8' - 0"	7' - 3"	35,500
E2000 LP (Low Profile)	17' - 7"	8' - 0"	6' - 5"	45,000
E2000 DW	12' - 2"	8' - 0"	8' - 9"	40,000
E2600 G (General)	15' - 6"	8' - 0"	8' - 9"	47,000
E3000	17' - 7"	8' - 0"	8' - 9"	59,000
E4000	23' - 1"	8' - 0"	8' - 9"	72,000
E5000	28' - 7"	8' - 0"	8' - 9"	87,500
E6000	34' - 1"	8' - 0"	8' - 9"	101,000

- The above sizes are typical, however some plants may not offer all tank sizes listed above. Other multi-compartment combinations are also available. For additional sizes, or specific application needs, please contact your Convault® distributor/salesman.
- Nipple layout and design vary according to customer needs.
- * **NOTE:** These are nominal weights of the tanks. Check with your distributor/salesperson for accurate tank weight.

Figure No. 5
Cylindrical Tanks Weights and Dimensions *

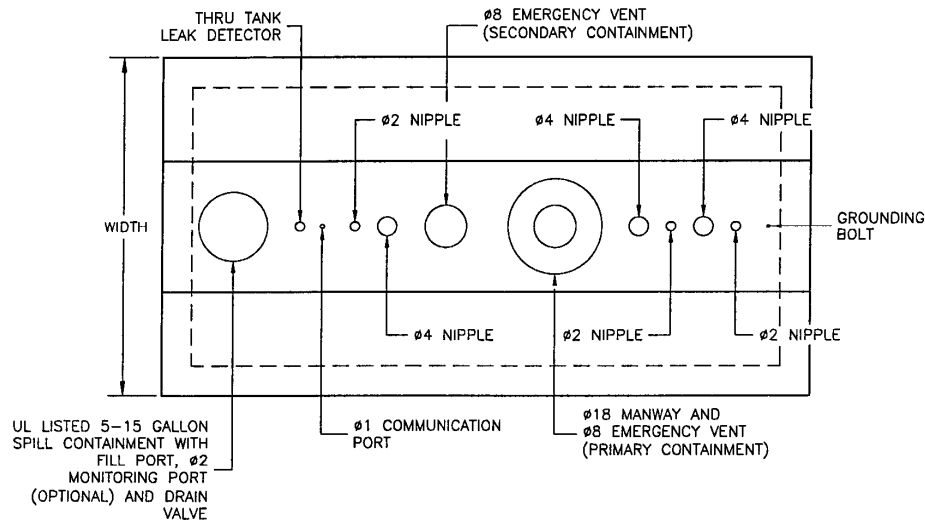
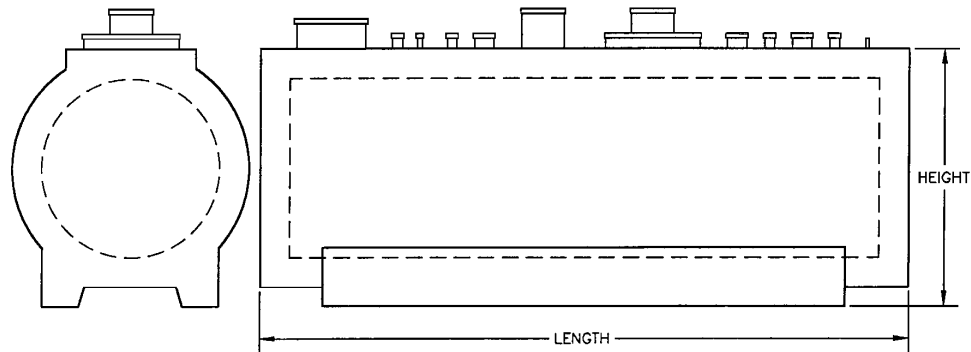

Single Compartment

SIZE	LENGTH	WIDTH	HEIGHT	WEIGHT
4000	11' - 11"	9' - 2.5"	9' - 4.5"	46,000
5200	15' - 1.5"	9' - 2.5"	9' - 4.5"	52,000
6000	17' - 3"	9' - 2.5"	9' - 4.5"	62,000
8000	22' - 7"	9' - 2.5"	9' - 4.5"	76,000
10000	27' - 11"	9' - 2.5"	9' - 4.5"	98,000
12000	33' - 3"	9' - 2.5"	9' - 4.5"	111,000

- Cylindrical tanks are only available from certain manufacturing locations. Check with your Convault® distributor/salesman for availability in your area.
- Multi-Compartment tanks are also available.
- Nipple layout and design vary according to customer needs.
- * **NOTE:** These are nominal weights of the tanks. Check with your distributor/salesperson for accurate tank weight.

Permits and Approvals

Installation of fuel/oil storage systems requires approval process from various government agencies. **List 1** shows typical approval process and documents needed. Specific local or Authorities Having Jurisdiction requirements may slightly differ for different locations, but the list is a good reference and a guide for your permits requirements.

List 1

PERMITS AND APPROVALS

1. Prepare state and/or local application forms.
 2. Prepare system detail drawings.
 3. Prepare the site plan as follows:
 - a. Draw to scale
 - b. Show property lines and indicate occupancy or use of adjacent property.
 - c. Show streets, intersections, and railroads.
 - d. Show buildings on the site and indicate type of construction. Show building openings on walls adjacent to tanks.
 - e. Show important utility lines, sewer, water, gas, and electric including fire hydrants and catch basins.
 - f. Show any nearby waterways, streams, rivers, lakes, or retention basins.
 - g. Show any underground or aboveground tanks.
 - h. Show new tank location and indicate shortest distance to buildings and property lines.
 4. **Prepare system detailed drawings to scale and show:**
 - a. Tank size, dimensions, and spacing between adjacent tanks.
 - b. Base slab dimensions and bollard location and size.
 - c. Vent size and location, including height of standard vent and type of cap.
 - d. Fill details including spill and overflow protection.
 - e. Piping details including shutoff valves and anti-siphon valves.
 - f. Pumps and dispensing equipment including location, size, and type.
 - g. Electrical details including shutoff switch location and grounding wire.
 - h. Level gauges and leak detection equipment.
 - i. Signs and decals.
- **NOTICE: It is advisable for the owners/operators to become familiar with the codes and regulations applicable to their operation. List 2 shows some of the codes and regulations governing aboveground storage tanks.**



List 2

CODES, REGULATIONS, AND GUIDELINES

Aboveground Fuel Storage Tanks (ASTs) fall under a variety of governmental jurisdictions; therefore, the following references are provided as a general outline. You may be subject to different legislation and governing bodies' requirements in your specific locale. A preliminary investigation must be conducted to thoroughly understand the controlling factors prior to utilizing the product in your specific area.

FEDERAL REGULATIONS

40 CFR 112, US Coast Guard, Environmental Protection Agency (EPA) and Occupational Safety and Health Administration (OSHA)

- **NOTICE: Among other requirements, EPA requires most aboveground storage tank installation sites to have a Spill Prevention, Containment and Countermeasures (SPCC) plan. The plan for tanks over 10,000 gallons must be certified by a professional registered engineer.**

STATE REGULATIONS

Federal regulations are referred to the governor of each state with the instructions that delegated duties to subordinate state agencies must provide a written plan on how the individual state will comply with the EPA's enforcement activities.

CODES AND STANDARDS

NFPA 30, and 30A, Flammable and Combustible Liquid Code
ICBO Uniform Fire Code and section 79 APPENDIX A - II - F of 1996 UFC
Building Officials and Code Administration (BOCA)
Southern Building Code Congress Institute (SBCCI)
International Fire Code (IFC)
Underwriters Laboratories (UL)
Underwriter's Laboratories Canada (ULC Standards/ORDs)

ENVIRONMENTAL CAVEAT

Several regulatory agencies have been integrally involved in the development of the Convault® aboveground storage tanks.

LIMITED WARRANTY

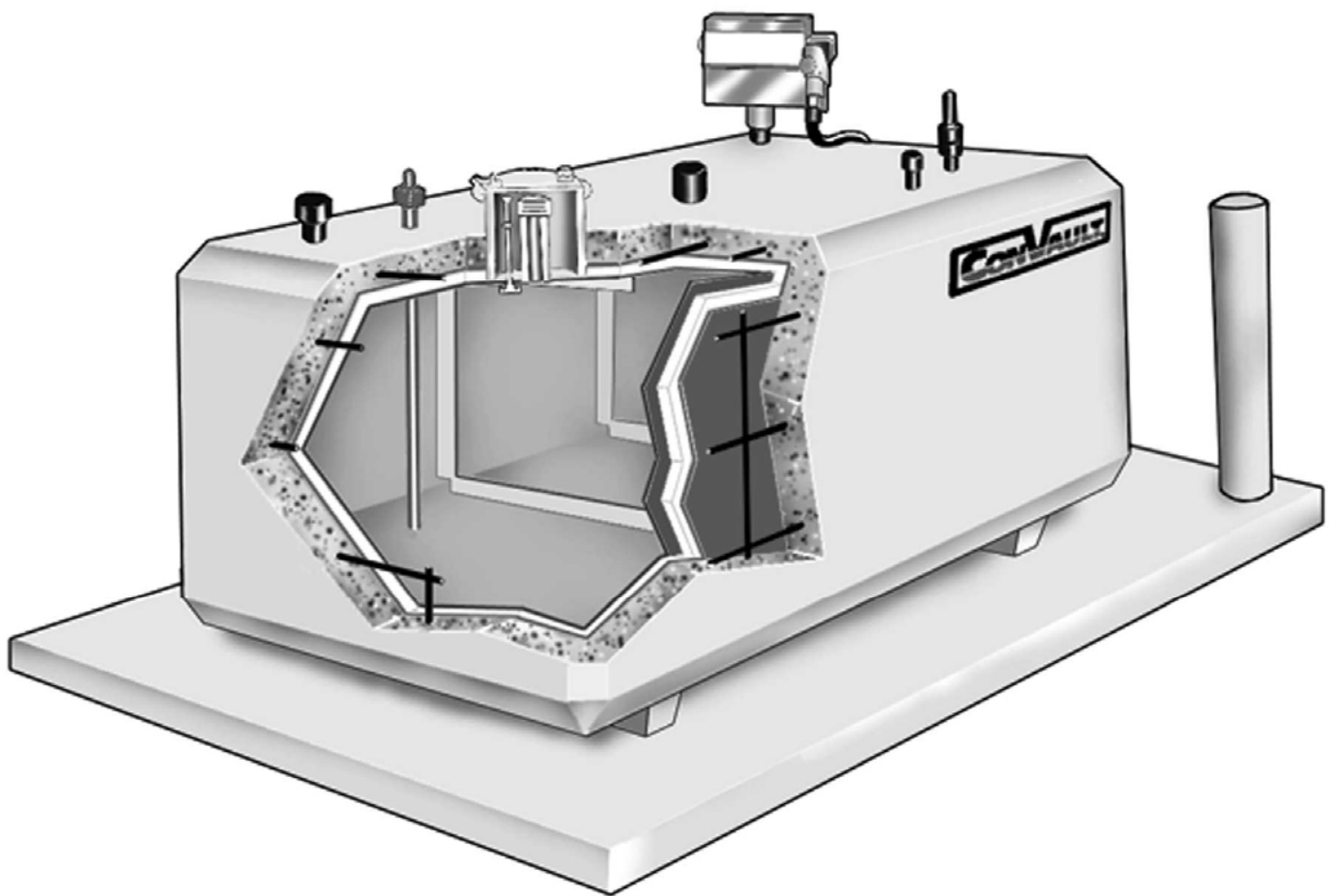



LIMITED WARRANTY

ConVault, Inc. warrants each CONVAULT® tank against defects in material or workmanship to the original owner from the date of purchase, for a period of twenty (20) years or thirty (30) years depending on model number of the tank. ConVault agrees to repair or replace any defective unit without charge provided that the tank is operated and maintained in accordance with the manufacturer's Owner's Manual except as set forth herein: **FAILURE TO INSTALL IN ACCORDANCE WITH MANUFACTURER'S INSTRUCTIONS WILL VOID THIS WARRANTY.** If the ConVault® tank is moved from its original installation, it must again be installed in accordance with manufacturer's instructions and ConVault, Inc. must be notified of the move and the new location.

CONVAULT® tanks are designed for storage of products compatible with steel. CONVAULT® tanks are not designed for storage of corrosives or toxic materials. To continue this warranty in effect, the user has a duty to conduct visual inspections at least weekly to check for leaks and to maintain the CONVAULT® tank in accordance with the Owner's Manual in effect on the date of shipment from the manufacturer. The primary tank must be inspected monthly for the presence of water and any water found must be removed. In the event leaks are determined, ConVault, Inc. must be contacted within two (2) working days at the following toll free number: 800-222-7099 or at 209-632-7571. This warranty does not cover damage resulting from accident, misuse or abuse, lack of reasonable care, or acts of God. This warranty is limited to the tank only and does not include paint, signs and decals, vents, pump, or any other accessories affixed to the tank. This warranty does not cover transportation cost of the replacement tank, the cost of labor or any other installation costs. Small cracks in concrete result from normal expansion and contraction and are not covered by warranty. Such cracks will not affect primary or secondary containment or fire retardation abilities of the tank. The limited warranties set forth herein are subject to the manufacturer receiving full payment for the products covered in this warranty.

THIS WARRANTY IS LIMITED TO REPLACEMENT OR REPAIR OF THE CONVAULT® TANK AT THE OPTION OF CONVAULT, INC. AND EXCLUDES ANY OTHER OR FURTHER REMEDIAL MEASURES. NO RESPONSIBILITY OR LIABILITY IS ASSUMED FOR ANY SPECIAL, INCIDENTAL OR CONSEQUENTIAL DAMAGES. Under no circumstances, shall the liability of CONVAULT® under this warranty, exceed the original purchase price of the tank. There are no warranties, which extend beyond the face hereof.

You may obtain warranty service by contacting any dealer of ConVault, Inc.

For testing purposes, CONVAULT® primary tanks may be pressurized up to 3 psig only, provided, however, that after flammable or combustible liquids have been placed in the tank, the tank shall be pressurized using inert gases such as Nitrogen. If any additional testing is required, please contact ConVault, Inc. for instructions prior to testing.

You may fill out the Warranty Validation Card on line or download a printable form at <http://www.convault.com>.

INSTALLATION INSTRUCTIONS

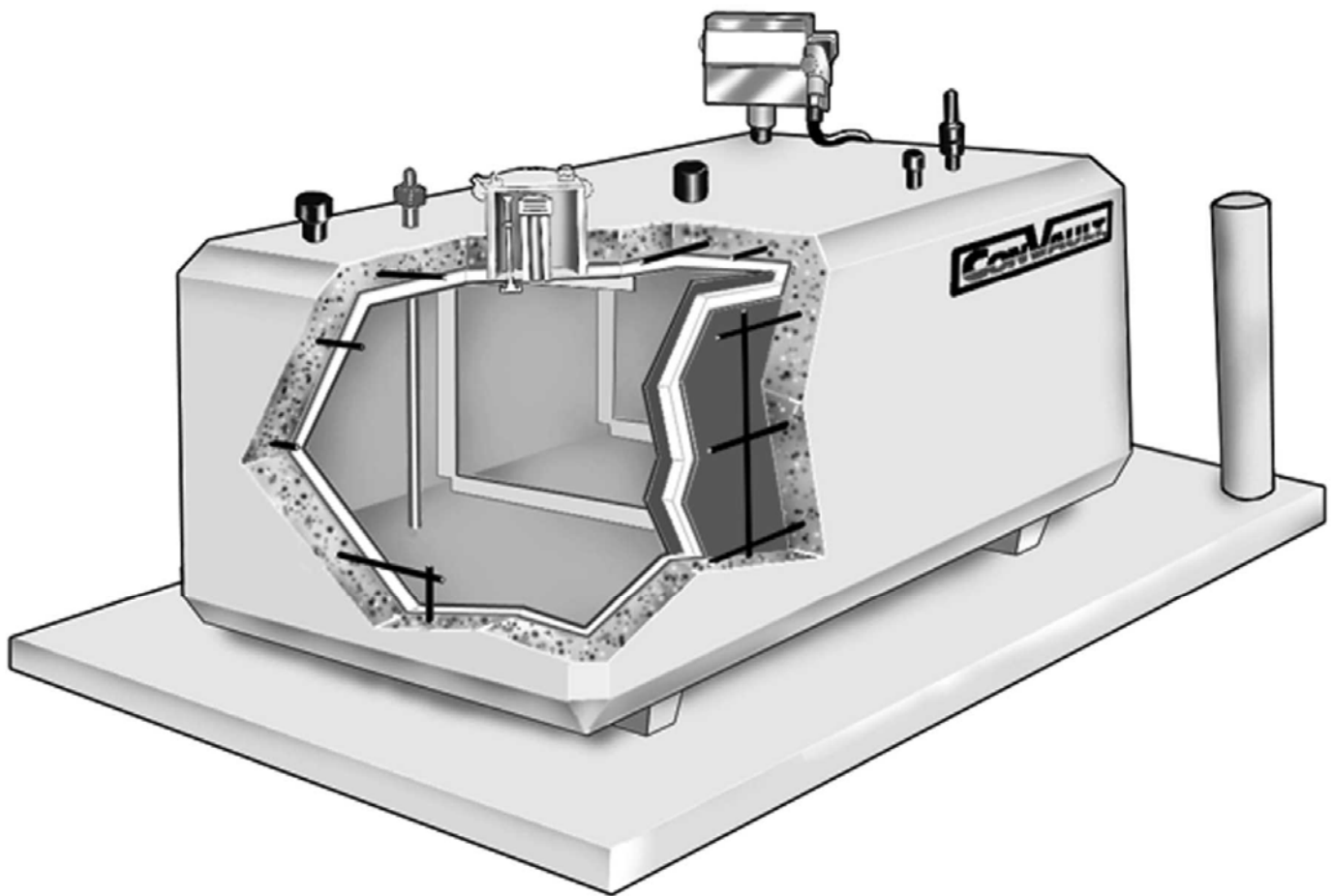



TABLE OF CONTENTS

	Page No.
A. SCOPE	23
B. PERMITS AND APPROVALS	23
C. TANK SITE	24
D. BOLLARD INSTALLATION	25
E. FOUNDATIONS	26
F. TANK HANDLING	27
G. TRANSPORTATION	28
H. UNLOADING AND SETTING	28
I. EQUIPMENT REQUIRED AND PROCEDURES	29
J. GROUTING OF LEGS	31
K. ELECTRICAL	32
L. PIPING	32
M. GENERAL APPLICATION REQUIREMENTS	33
N. DISPENSING APPLICATIONS	34
1. On Tank Suction Type Dispensing Application	34
2. Side Mount Suction Type Dispensing Application	35
3. Off Tank Suction Type Dispensing Application	36
4. Submergible Pump Dispensing Application	37
O. GENERATOR FUEL SUPPLY APPLICATION	38
P. USED OIL	41



A. SCOPE

1. These instructions apply to stationary, shop fabricated, aboveground, concrete encased steel tanks for the storage of stable, flammable and combustible liquids at normal atmospheric pressure. Because the tank installation is a specialized skill, it is assumed that those using these instructions will have knowledge of, and possess the skills and equipment necessary to install this type of aboveground storage tank properly and safely.
- **NOTE: Consult the Authorities Having Jurisdiction to insure compliance with local codes and regulations prior to carrying out any instructions given herein.**

B. PERMITS AND APPROVALS

1. Because of the combustible and flammable nature of the hydrocarbon liquids stored in the Aboveground Storage Tanks (AST), they are subject to various codes, and regulations. The codes and regulations govern the fabrication, testing, shipment, installation, operation, and maintenance of the tanks. The codes and regulations may originate from local fire authorities (e.g. Fire Marshals), local building jurisdictions (e.g. city or county building officials), state laws and regulations (e.g. Air Resource Board), Federal agencies (e.g. Environmental Protection Agency) and regional and national codes (e.g. National Fire Protection Association (NFPA), Uniform Fire Code (UFC), or International Fire Code (IFC).
2. Installation, operation and maintenance of the tanks must be carried out in accordance with the applicable codes and regulations. These aboveground storage tanks are intended for installation in accordance with NFPA 30, NFPA 30A, UFC (including article 79 Appendix A-II-F), and IFC.
3. System installation starts with obtaining the required state and local permits.
4. Typical approval process and documents needed are shown in the **List 1, Page 17, Product Description**. Specific local or jurisdictional requirements may slightly differ from location to locations but the list is a good reference and a guide for your permit requirements.
5. State and local permit applications must be made with the current and up-to-date forms.
6. Zoning permits may also be required.



C. TANK SITE

- **NOTE:** The location of each ConVault® tank is stored in ConVault, Inc.'s central data bank. If the tank is to be relocated to a different location, ConVault, Inc. must be properly notified to update the data bank. The product limited warranty could be voided if ConVault® is not informed of tank relocation or if tank is not reinstalled in accordance with these installation instructions. It should be noted that ConVault® Warranty is conditional on installation of tanks in accordance with ConVault® Installation Instructions. Your attention is specifically drawn to the tank site selection and foundations requirements.

⚠ WARNING Follow the instructions enumerated below. Failure to follow these instructions may result in death or serious injury.

1. Tank location and foundation to comply with the current edition of the Uniform Building Code (UBC) and all applicable local codes and ordinances. For sites subject to ground frost, the foundation slab design should be reviewed to take into consideration frost line requirements.
2. The tanks should be located a minimum of 1/3 the height of the vault away from down slopes - greater than 3:1, and 1/2 the height of the vault away from up slopes smaller than 3:1.
3. Tanks located in areas subject to flooding must be protected against floatation. Flood resistant tie-down brackets are available for all tank sizes to resist floatation during complete submergence.
4. Aboveground storage tanks should not be located over underground utilities or directly beneath overhead power and telephone lines.
5. The tank should be protected from vandalism and accidental damage in accordance with all the applicable codes.
6. Fire department vehicle access should be provided within 150 feet of any tank.
7. The venting of a tank to a remote location must include the use of a steel pipe equal to or greater in size than the vent outlet, and the methods of supporting such piping against displacement must comply with local codes. Provide the vent piping with a slope to ensure that all condensed vapors drain back to the tank.

D. BOLLARD INSTALLATION

Collision protection is recommended on sides of the tank exposed to traffic. This is generally accomplished with pipe bollards. Always check state and local codes. Sample installations are shown below:

Spacing from the tank should conform to the applicable code requirements.

As an alternative to steel pipes, you may use precast concrete barriers. You can obtain the precast barriers from your Convault® representative.

Figure No. 6
Sample Bollard Installation

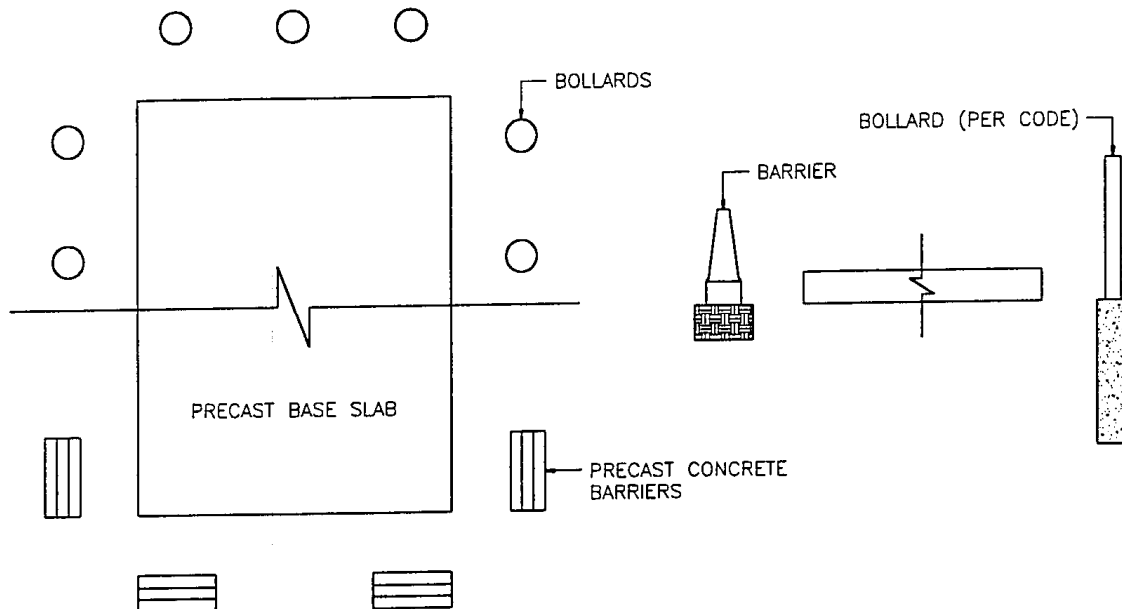



E. FOUNDATIONS

CAUTION Failure to provide proper foundation may result in damage to the tank and equipment affixed to it and may void the tank warranty.

1. Tank location and foundation must comply with requirements of the current edition of the relevant building code and all the applicable local codes and ordinances.
2. The tank slab may be poured in place using the Convault standard slab drawing, which may be obtained by contacting Convault or your local representative. An alternative to pouring the slab in the field is to purchase a precast slab from the manufacturer.
3. The foundation for the tank must be designed to support the tank plus the weight of the maximum amount of product the tank will be storing. The foundation design must also include provision for draining surface water away from the tank to minimize the risk of fuel accumulation under the tank from an overflow or spills.
4. Tanks located in areas subject to earthquake must be protected against seismic forces. Optional earthquake restraints are available. The restraints can be retrofitted to the slab should local requirements change. The restraints are mounted on the slab and are secured with anchor bolts directly into the slab. The tank feet rest in the restraints and do not require bolting directly to the tank. Insure that the slab is large enough to accommodate earthquake restraints or hold-downs.
5. Tanks located in areas subject to hurricanes may be required by your local Authority Having Jurisdiction (AHJ) to be fitted with hurricane hold down restraints.
6. The tank foundation is to sit on undisturbed earth or compacted fill, free of organic material.
7. The following minimum soil characteristics may be used if the Convault® tank is installed on a continuous solid slab which will uniformly distribute the weight of the tank and its contents to the soil:
 - a. Bearing Capacity: minimum 1,000 but preferably 2,000 lb. per sq. ft.
 - b. Total settlement: 1 inch maximum.
 - c. Differential settlement: 1/2 inch maximum.

- d. Provide a minimum six-inch (6”) thick granular sub-grade, compacted and graded to a level uniform subsurface prior to the cast slab placement or pouring of the cast-in-place slab.
- e. A geological engineer should evaluate the effect of the water table and frost lines if such unusual conditions exist at the site.
- f. Soil surface and granular sub grade under foundation should be flat within 1/16” per foot. Soil around foundation should be sloped away 1/8” per foot minimum for 5 feet.
- **NOTE:** If Bearing pads are used under the tank legs instead of grouting, the tank foundation and slab should be designed to withstand concentrated loads under the bearing pads. For grouting instructions see paragraph J on Page 31.
- **NOTE:** The above soil characteristics, foundation and slab design requirements may be revised by a qualified design engineer who would design the foundation and the slab on a site-specific basis.
- **NOTE:** Some Authorities Having Jurisdiction require up-lift restraints for areas subject to flooding and hurricanes.

F. TANK HANDLING

▲WARNING Failure to obey the following tank handling instructions may result in death or serious injury.

- **NOTE:** Do not handle or install tank without having knowledge and experience in procedures involved with proper and safe installation of an aboveground tank used for storage of flammable and combustible liquids. Reliance on skilled and professional installers is an important factor in avoiding damage to tank and system failure.
1. Equipment required in the shipping and off-loading of Convault® aboveground storage tanks include lifting straps, nylon tie-down straps, crane, forklift, and carpet remnants strategically placed on the bevels to prevent the tie-down straps from scraping the paint loose while the tank is en-route. **See also Equipment Required and Procedures Page 29.**
 2. Do not drop or drag the tank. Dropping or dragging a tank may result in damaging the tank beyond repair and voiding the Convault® Limited warranty.



3. Do not handle or move the Convault®, unless it is empty. Under no circumstances should a tank containing petroleum product be moved.
4. If petroleum product has been introduced in the tank, first empty and cleanse the tank, then relocate using the Department of Transportation Guidelines for transporting fuel containers.

G. TRANSPORTATION

It is important that Convault® tanks are properly lifted and loaded on trailers and flat beds. The tank should be supported on solid lumber under the far two legs. The tank should be properly secured to prevent sliding and undue vibration from the road.

CAUTION Convault® 8,000 through 12,000-gallon tanks are provided with three legs. The middle leg is approximately ¾” shorter than the other two. The middle leg is made shorter to prevent the tank from damage caused by vibration while being transported. Therefore, the middle leg should not be supported on the trailer or on the flatbed. Supporting the third leg during transportation may result in property damage.

H. UNLOADING AND SETTING

WARNING Failure to provide adequate equipment and proper procedures for unloading and setting the tank may result in death or serious injury.

1. The unloading equipment and procedures are critical to setting the tank safely and without harming the people or damaging the tank.
 - **NOTE:** The most important aspect of a job procedure is **SAFETY**. Please ensure that every step of this procedure is carried out with safety first in mind.
2. Tanks Weight and Dimensions.

Please refer to **Figures No. 2, 3, 4 and 5** in **Product Description, pages 13 through 16**. For actual tank weights and dimensions, please contact your Convault® distributor.



I. EQUIPMENT REQUIRED & PROCEDURES

1. Following is a list of equipment that may be required to handle a Convault® tank:
 - a. A crane or a forklift of sufficient capacity to safely lift and place the unit.
 - b. Slings minimum 20 feet long each and rated for the tank weight. The angles between the slings should be at least 50 degrees.
 - c. 4-way spreader.
 - d. Miscellaneous shackles, tag lines, and rigging tools.
2. Note the following guidelines to handle and install a Convault® tank.
 - a. Plan the required crane and rigging capacity to safely unload the tank.
 - b. Inspect the tank on the delivery truck prior to unloading. Report any damage in transit to the truck driver and note on the shipping ticket.
 - c. Allow sufficient crane time for installing the load block and organizing the rigging.
 - d. During unloading and setting, allow one person in-charge to signal the crane operator. Keep people clear of the load and avoid being trapped between the load and building walls and equipment.
 - e. Make sure there is no overhead wiring to interfere with crane or boom operation. Provide sufficient room for cranes and boom trucks to off load.
 - f. Department of Transportation prohibits transportation of tanks with product and warning labels. Product and warning labels should be installed on site. If installed at the plant, they should be masked prior to shipment. Labels and decals must be placed on the tank in accordance with **Figure No. 7** page 30.

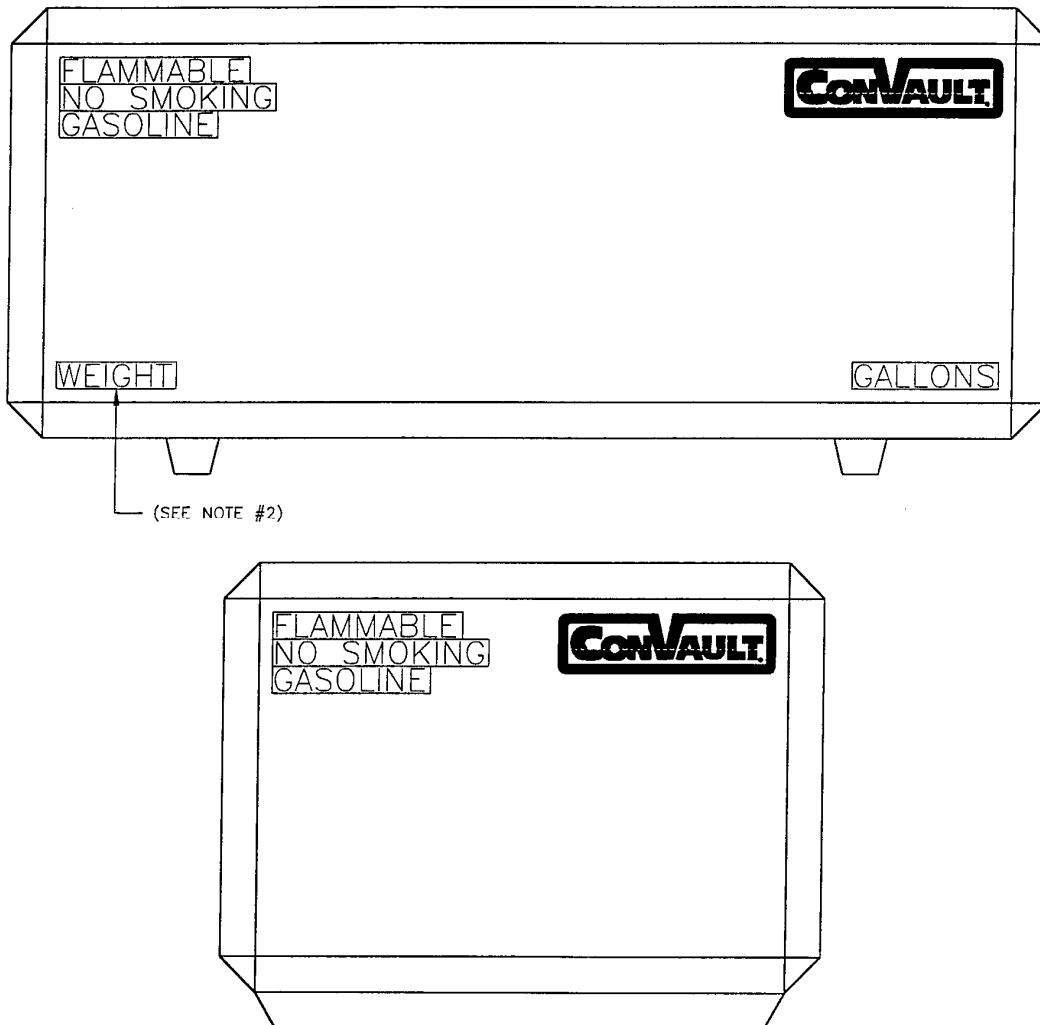
Figure No. 7**NOTES:**

1. For best results, attach decals or signs at 60° – 70° F.
2. Empty weight.
3. ConVault logo to be located in upper right corners.
4. NO SMOKING, FLAMMABLE or COMBUSTIBLE and "product" signs to be located in upper left corners.
5. Capacity signs to be located in lower right corner of long sides.
6. Weight signs to be located in lower left corner of long sides.
7. FILL, VENT, EMERGENCY VENT, LEAK DETECTOR TUBE, Do Not Drill..., Caution: This Tank..., signs to be located along upper bevel near corresponding nipples.
8. Warning: Death May Occur... sign to be located on top of tank near manway, if applicable.



J. GROUTING OF LEGS

1. All tanks larger than 2000 gallon must be grouted with non-shrink grout to the concrete slab or supported with alternative engineered pad interface.
2. We recommend grouting the legs of all tank sizes, which will provide a uniform load distribution on legs and foundations.
3. Neoprene pads may be used instead of grouting in accordance with the manufacturer's recommendations. Pads should be neoprene with 50 durometer Type A hardness. The physical properties of neoprene pads should meet or exceed AASHTO specifications M251, Sections 18, 25. For specifications and installation instructions of neoprene pads contact your ConVault® representative.
4. Also, see Notes on page 27 under FOUNDATIONS.

⚠ WARNING There is potential for serious injury or death should someone access the top of the tank without appropriate ladders, stairs or fall protection. For ConVault tank models with heights above 4 feet, ladders, stairs, guardrails or equivalent fall protection systems must be used if a person accesses the top of the tank.

K. ELECTRICAL

- **NOTE:** Our intention is for our tanks to be installed in accordance with national, state and local rules, regulations and fire codes requirements. Please follow the following order of priorities.
 - a) Local jurisdiction codes, rules and regulations.
 - b) Applicable state codes, rules and regulations.
 - c) Applicable regional and national codes, rules and requirements.
 - d) Manufacturer's recommended installation, and operating procedures.
 - e) ConVault® operating manual.
1. Electrical service and fuel piping to the pump units should be installed in accordance with the requirements of National Electric Code (NEC)- NFPA 70 and local requirements.



2. All electrical devices used with or located within twenty (20) feet of the Convault® tank should conform to NEC Hazardous Locations.
3. An emergency shut-off switch is required to be mounted in a location visible from the dispenser. The switch is normally mounted on a building wall or a post. The switch must be marked as an emergency shut-off switch, in accordance with NEC.
4. Pumps and all other equipment used in the hazardous area should be rated by UL or Factory Mutual (FM).
5. Electrical grounding is required for flammable liquid fuel tanks. Convault® Tanks are provided with two grounding bolts welded to the steel tank or lugs welded to the nipples on tank top. Installation of grounding shall be in accordance with the NFPA 780 code. **See Appendix B** of this manual for a summary of **Lightning Protection Installation Instructions**.

L. PIPING

1. Piping on Convault® tanks will mainly depend on dispensing method considered for your facilities. Several methods are suggested below. You should note that dispensing methods suggested here are schematic only and they are not detailed installation drawings. You should engage an engineer/designer to design the piping arrangement and make sure they are in accordance with the applicable codes, rules and regulations. Please also make sure you check with your Authorities Having Jurisdiction and find out which codes and regulations are applicable to your area.

CAUTION Do not connect any fuel return or vapor recovery pipe to leak detector tube or communication nipple. Failure to comply will result in filling the interstice with fuel and consequently voiding your warranty. The leak detector tube and the communication nipple are powder coated red for easy identification.



M. GENERAL APPLICATION REQUIREMENTS

1. The following requirements apply to **all applications**:
 - a) Fuel tank shall be located with set backs from buildings, property lines and public highways in accordance with state and local codes.
 - b) Emergency venting device shall be installed on the emergency vent pipe nipple prior to use. See also paragraph H.2 on page 48 for operation.
 - c) Pressure vacuum vent (PV) caps shall be installed on normal vent.
 - d) Phase I vapor recovery system shall be installed, if required by the Authorities Having Jurisdiction.
 - e) Net positive suction head (NPSH) problems and cavitation may occur in extremely high altitudes or as a result of long suction piping. In these cases, use of submersible pump should be considered.
 - f) Fire extinguishers shall be provided as required by the applicable fire codes.
 - g) A cleanup kit shall be provided at the site.
 - h) Always consult Authorities Having Jurisdiction.

2. The following requirements apply to **Dispensing Applications** shown in **Figures 8 through 11**:
 - a) Dispensing shall be by a UL/ULC listed pump equipped with:
 - i. Vacuum breaker
 - ii. Filter and adapter
 - iii. UL listed fuel hose
 - iv. Safety breakaway valve
 - v. Auto shutoff nozzle
 - b) Phase II vapor recovery system shall be installed, if required by the Authorities Having Jurisdiction.
 - c) Any pump described as “remote” must be approved by the Authorities Having Jurisdiction in advance of the installation of the pump.

3. The following requirements apply to **Generator Fuel Supply** shown in **Figures 12, 13 and 14** and recommended piping shall include:
 - a) Angle check valve with pressure relief or foot valve, strainer and pressure relief valve.
 - b) Shut-off valve with fusible link on supply piping
 - c) Anti siphon valve if the level of the suction piping falls below the high level of fuel in the tank.

N. DISPENSING APPLICATIONS

1. On-Tank Suction Type Dispensing Application

Dispensing from the Convault® tank system is most simply accommodated by a top of tank pump. This arrangement eliminates leaking valves and fittings. Our recommended dispensing configuration is shown in **Figure 8**. Diagram provided is recommended for sites with tanks 2000 gallon and less that serve the end-user's internal fleet/vehicles. **See the General Applications Requirements in M.1 and M.2 on page 33.**

Figure No. 8

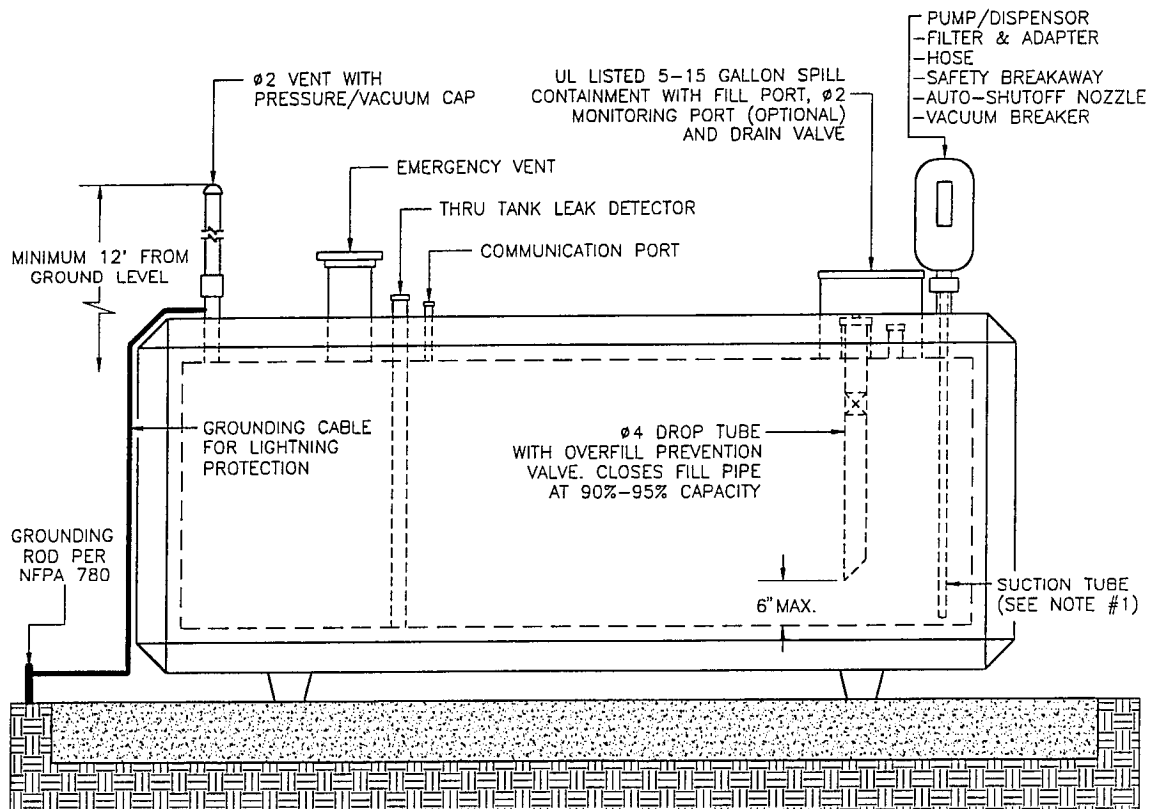

Notes:

1. Bottom of foot valve/strainer to be 1" from bottom of steel tank
2. Stairway assembly to fill port (optional)

2. Side-Mount Suction Type Dispensing Application

The diagram provided in **Figure 9** is recommended for the sites to dispense fuel to private user or for fleet vehicles. In addition to the **General Applications Requirements in M.1 and M.2 on page 33**, the system should be equipped with:

- a) Anti siphon valve with pressure relief or solenoid valve,
- b) Emergency shear valve, if required by Authority Having Jurisdiction.

Figure No. 9

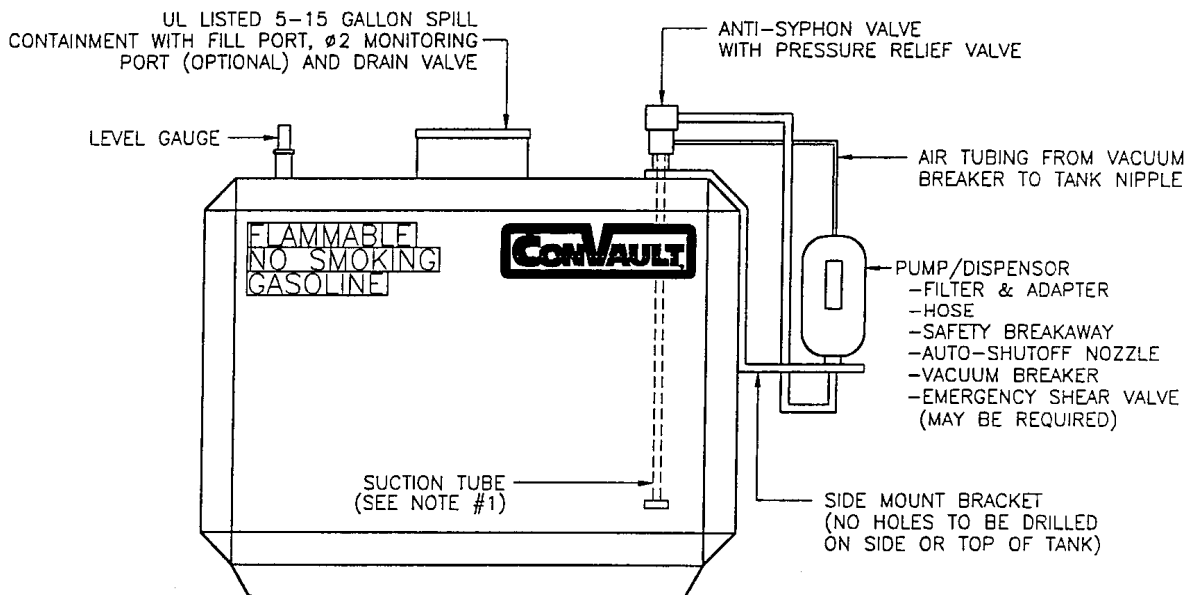

Notes:

1. Bottom of foot valve/strainer to be 1" from bottom of steel tank
2. Stairway assembly to fill port (optional)

3. Off-Tank Suction Type Dispensing Application

The diagram in **Figure 10** provided is recommended for those sites authorized to either: dispense to motor vehicles for public use or fleet vehicles with high-speed dispensing accessories. In addition to the **General Applications Requirements in M.1 and M.2 on page 33**, the system should be equipped with:

- a) Angle check valve or anti siphon valve with pressure relief,
- b) Under pump emergency shear valve, if required by Authority Having Jurisdiction.

Figure No. 10

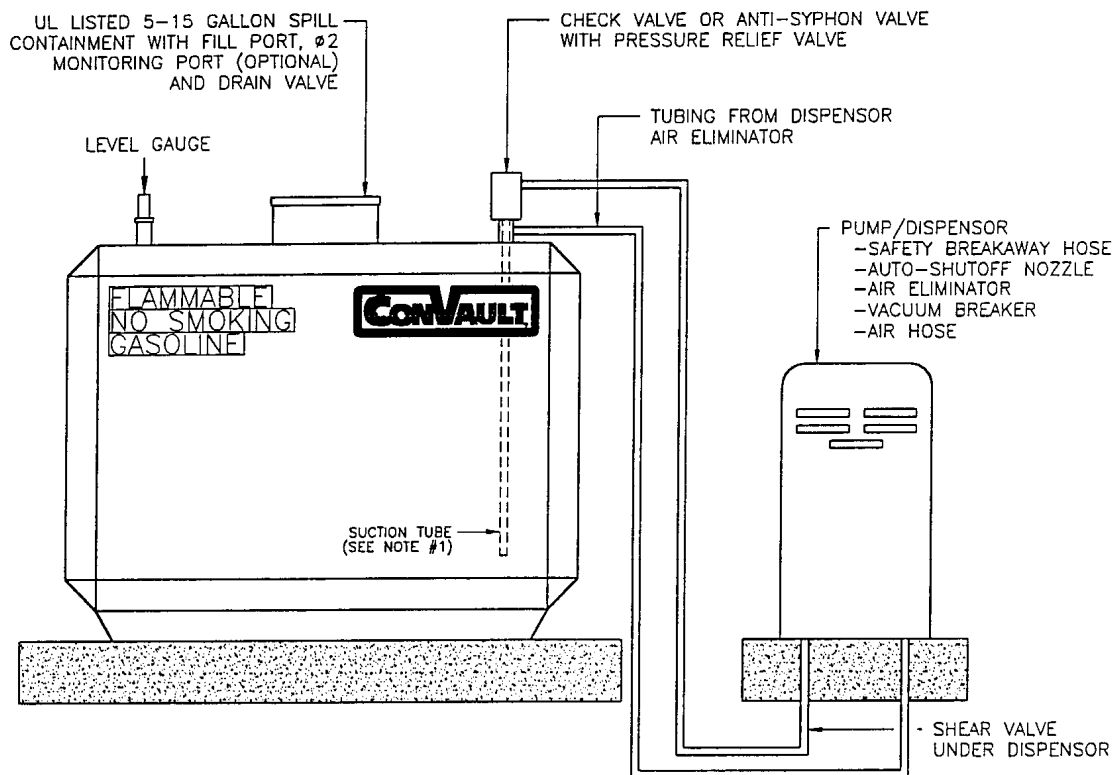

Notes:

1. Bottom of foot valve/strainer to be 1" from bottom of steel tank
2. Stairway assembly to fill port (optional)

4. Submersible Pump Dispensing Application

The diagram shown in **Figure No. 11** is recommended for those sites authorized to either: dispense to motor vehicles for public use or fleet vehicles with high-speed dispensing accessories. In addition to the **General Applications Requirements in M.1 and M.2 on page 33**, the system should be equipped with:

- a) Solenoid valve with pressure relief,
- b) Emergency shear valve, if required by Authority Having Jurisdiction,
- c) Submersible pump, which will require 220-volt electric supply.

Figure No. 11

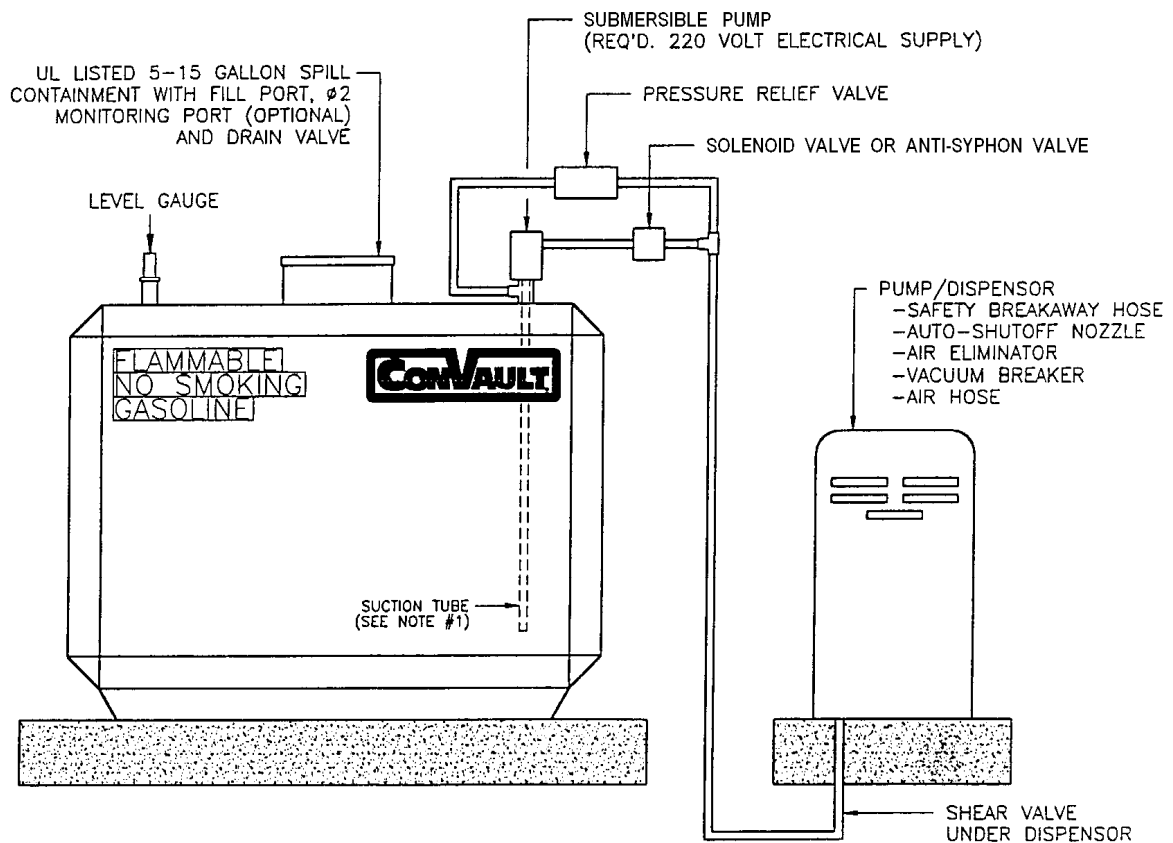

Notes:

1. Bottom of suction stub extended to 1" to 4" from bottom of steel tank
2. Stairway assembly to fill port (optional)

O. GENERATOR FUEL SUPPLY APPLICATION

The diagrams shown in **Figure No. 12, 13 and 14** are recommended for those sites utilizing a Convault® AST to supply a generator, whether it is primary or standby in function. **See also the General Applications Requirements in M.1 and M.3 page 33.**

For directions and side view, see Figure 12; for end view, see Figure 13; for option of using one connection for both suction and return lines see Figure 14.

Figure No. 12
Side View

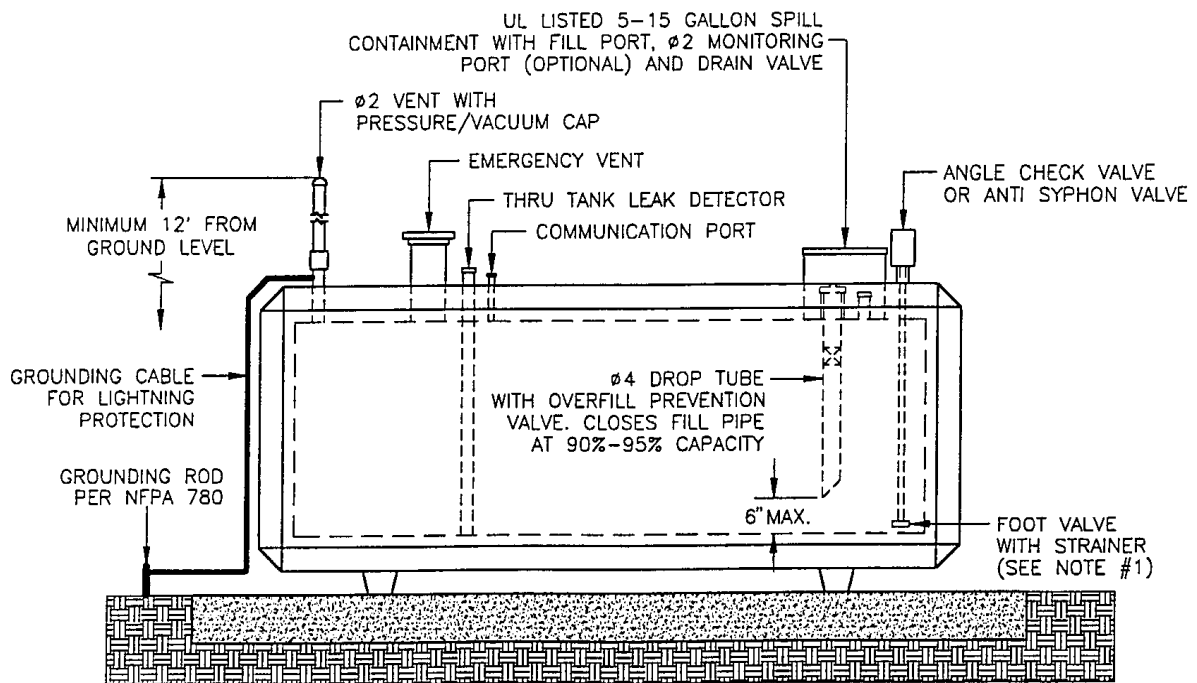

Notes:

1. Bottom of foot valve/strainer to be 1" from bottom of steel tank
2. Stairway assembly to fill port (optional)

See the General Applications Requirements in M.1 and M.3 page 33.

Figure No. 13
Generator Fuel Supply
End View

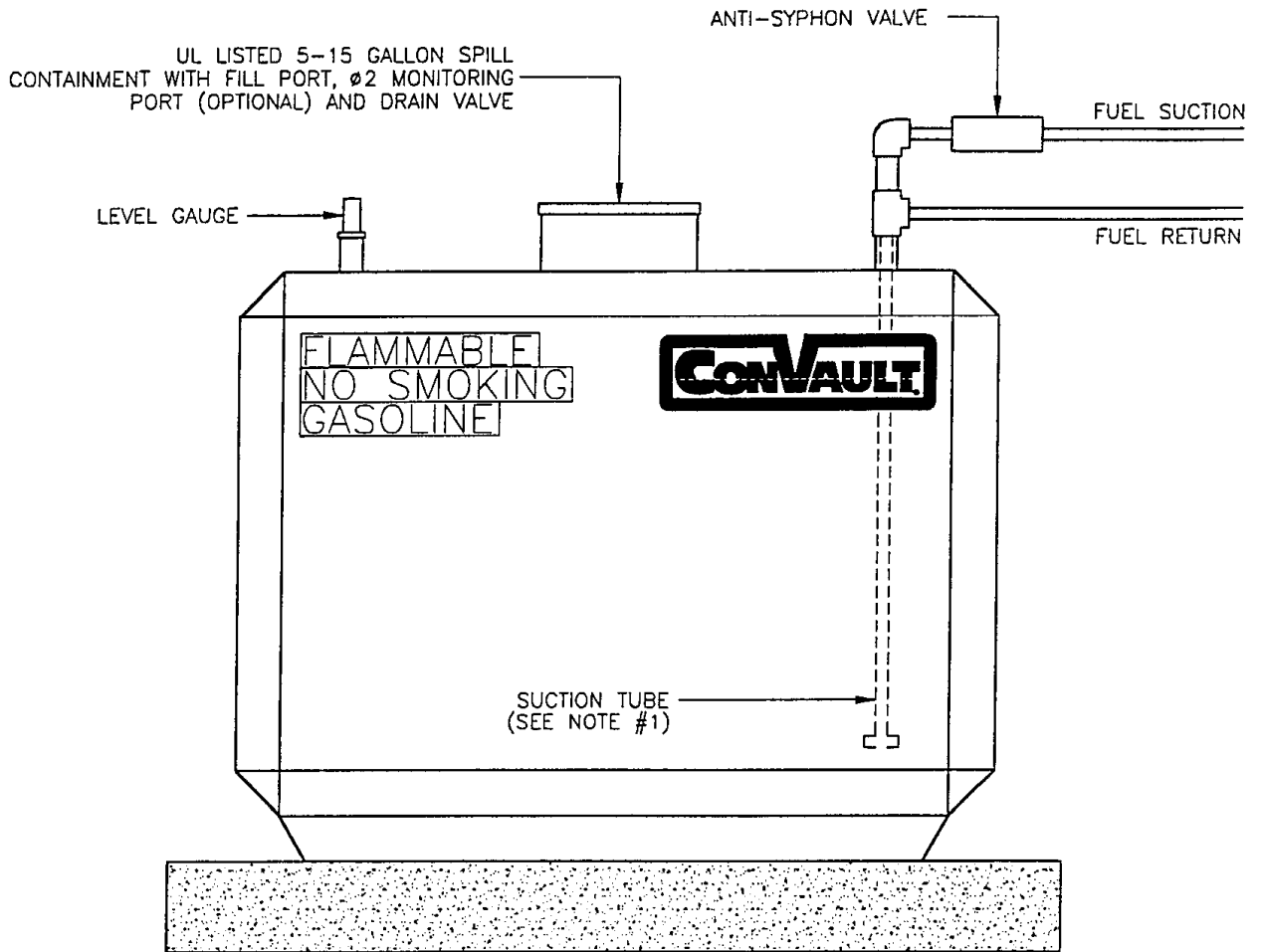

NOTES:

1. Bottom of foot valve/strainer to be 1" from bottom of steel tank
2. Stairway assembly to fill port (optional)

CAUTION Do not connect any fuel return or vapor recovery pipe to leak detector tube or communication nipple. Failure to comply will result in filling the interstice with fuel and consequently voiding your warranty. The leak detector tube and the communication nipple are powder coated red for easy identification.

Figure No. 14
Generator Fuel Supply
Optional use of one connection for both suction and fuel return line.

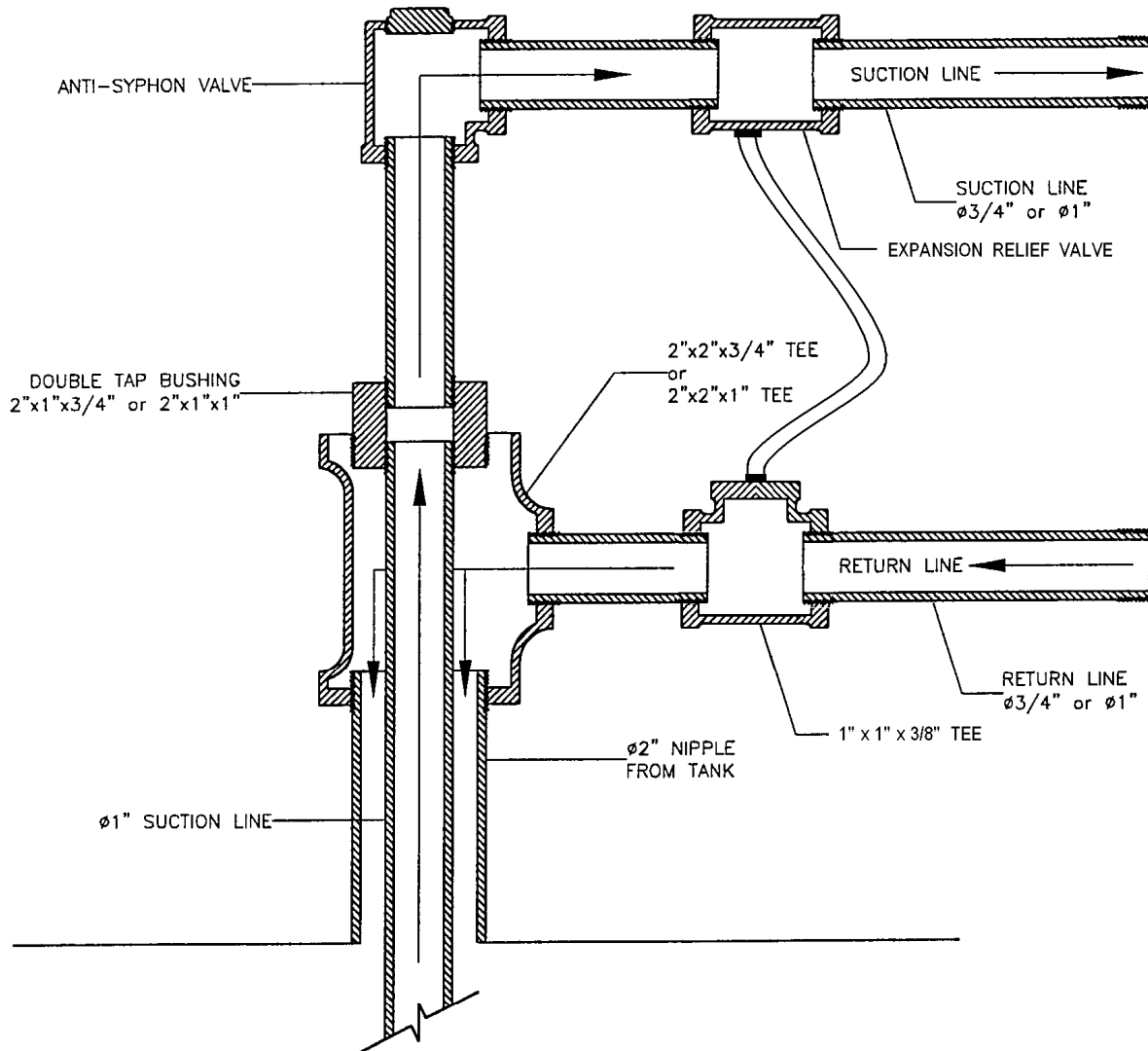

P. USED OIL APPLICATION

The diagram provided in **Figure No. 15** is recommended for use with used oil storage and is not a requirement. Confirm with the local Authorities Having Jurisdiction and ensure that all pertinent operational requirements have been met in advance of installation. **See also the General Applications Requirements in M.1 page 33.**

ConVault® recommends the use of a used-oil receptacle, stair clamps, and a step-platform for manual pouring sites. Where the tank is filled by a remote pump, an overfill prevention system should be utilized. ConVault® recommends the use of an audible alarm in conjunction with existing level indicator devices, as well as a solenoid valve in the fill pipe or shut-off switch to control the pump. Fire extinguisher and spill cleanup kit should be provided at the site.

Figure No. 15

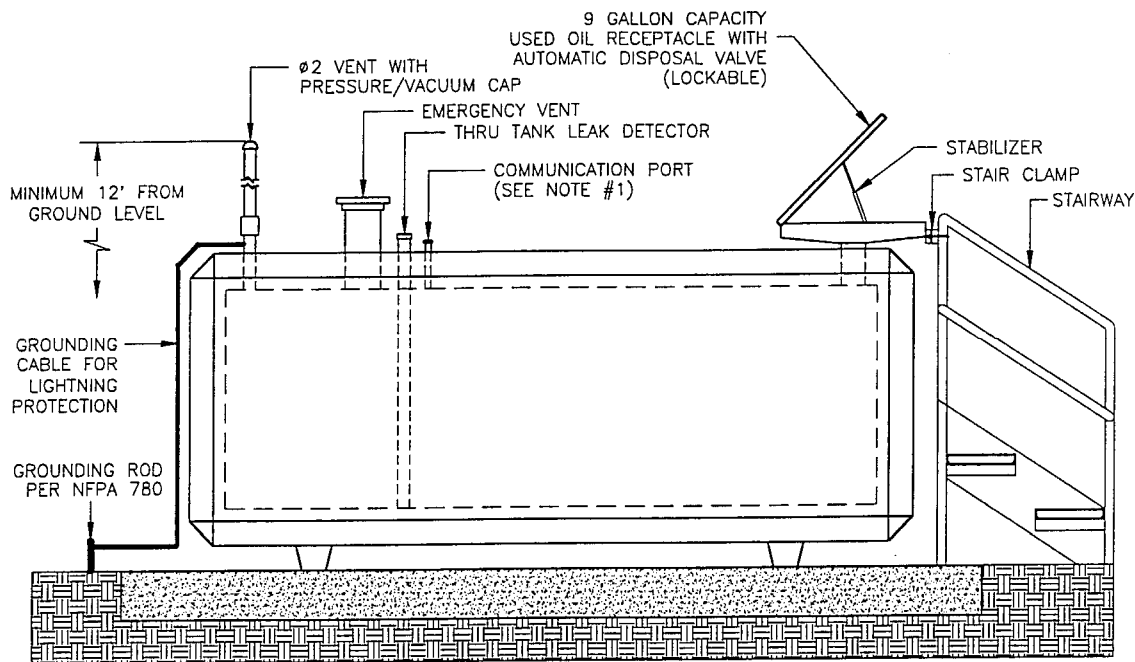

1. STAIRWAY ASSEMBLY TO FILL PORT (OPTIONAL)

OPERATING MANUAL

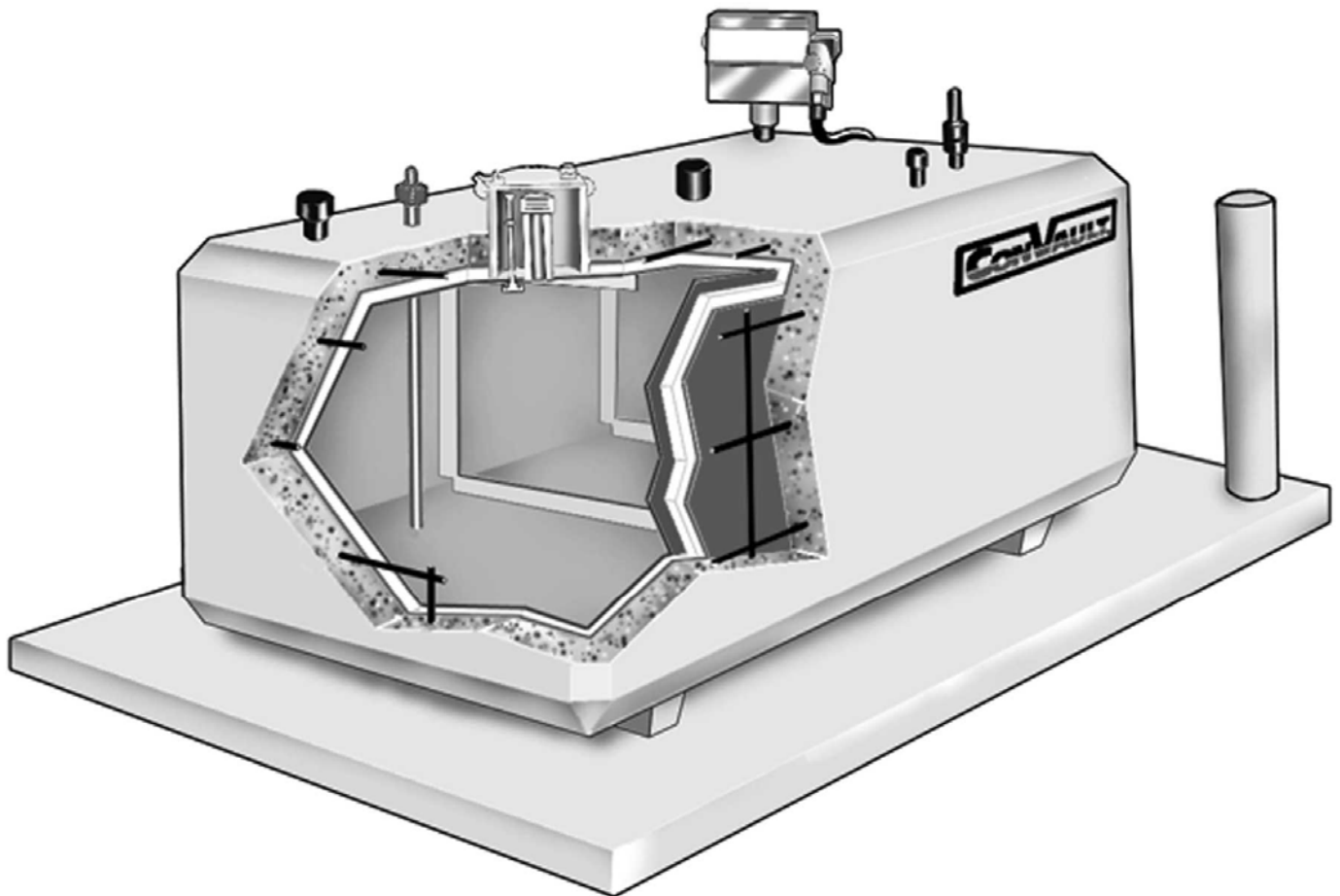



TABLE OF CONTENTS

	Page No.
A. GENERAL	44
B. FILLING THE TANK	44
C. GENERAL FIRE PROTECTION	45
D. LEAK DETECTOR	45
E. COMMUNICATION NIPPLE	46
F. FUEL DISPENSING	47
G. OVERFILL PROTECTION	47
H. VENTING	48
1. Atmospheric Vent	48
2. Primary Tank Emergency Vent	48
3. Secondary Containment Emergency Vent	48
I. SPILL CONTAINMENT	49
J. BACTERIA MONITORING AND CONTROL	49
K. WATER MONITORING AND CONTROL	49



A. GENERAL

Convault® tank is a steel storage tank insulated with Styrofoam and wrapped in a secondary containment consisting of 30 mil high density polyethylene membrane encased in a 6 inch thick reinforced concrete vault.

Since the tank contains flammable or combustible liquids, it is therefore prudent that general common sense is exercised in operating the fuel storage system. Dispensing of fuel from the Convault® storage tank to other equipment, automobiles, generators, etc., requires connection of accessories to the tank. Therefore it is important to establish practices and procedures to ensure that accessories and their piping connections are free from any leaks or other hazardous conditions.

- **NOTE: it is very important that you familiarize yourself with the fuel dispensing equipment and accessories and follow their manufacturer's operating instructions to their full extent. Equipment manufacturer's operating instructions, guidelines, and recommendations take precedence to the instructions contained in the Convault® operating manual. Use the following list as your order of priority:**
 1. **Local jurisdiction codes, rules and regulations.**
 2. **Applicable state codes, rules and regulations.**
 3. **Applicable regional and national codes, rules and requirements.**
 4. **Manufacturer's recommended installation, and operating procedures.**
 5. **Convault® operating manual.**

B. FILLING THE TANK

- **NOTE: Filling of tanks should be carried out under continuous and close supervision.**

Tank filling nipple is a threaded 4 or 6-inch pipe located inside the spill containment compartment. The filling nipple is located lower than the containment top to catch any potential spills.



CAUTION DO NOT ever use the 2” Leak Detector Tube or the 1” communication nipple for filling the tank. These nipples are not connected to the primary tank. They are powder coated red to distinguish them from all other primary tank nipples, which are coated black or white. If the leak detector tube or the communication nipple are used as filling ports, or connected to any other filling or vapor recovery system, the secondary containment will be filled with fuel or petroleum product vapors. This will invalidate your ConVault® Limited Warranty. It is essential that all operating personnel and fuel delivery truck drivers are trained and are made familiar with the proper filling operations.

- **NOTE:** Multi-Compartment tanks must be carefully labeled to prevent cross-filling the individual tanks; for example, a double 500 gallon tank should be labeled as diesel and gasoline to insure the operator or the fill truck driver can easily identify each compartment.

C. GENERAL FIRE PROTECTION

Smoking is prohibited within fifty feet (50’) of all storage and dispensing devices. Signs prohibiting smoking must be conspicuously posted.

Portable fire extinguishers must be provided for the suppression of fires in accordance with NFPA 10 and UFC for high hazard area. Additional fire control equipment might be required, if in the opinion of the fire official, an unusual fire exposure hazard exists.

D. LEAK DETECTOR

All ConVault® aboveground storage tanks are equipped with one or two Leak Detector Tubes to enable you to check and monitor any leaks from your primary steel tank into the secondary containment. The secondary containment consists of a 30-mil high-density polyethylene membrane encased in 6-inch thick concrete to provide 2-hour fire resistant vault for protection of primary and secondary containments.

The primary steel storage tank is shop-tested at 5 psig for 24 hours and is checked for leaks and any other damage before it is wrapped in the secondary containment. Under normal circumstances, the primary steel tank is not expected to leak.

Notwithstanding the above, the tanks should be visually inspected, on a weekly basis for any signs of leaks from the primary tank, pipes, fittings, and auxiliary equipment attached or connected to the tank.



The 2-inch leak detector tube is located on top of the tank and is powder coated in red to make it easy to identify. Except for a 1-inch communication nipple and the 2-inch leak detector tube, all other connections on the tank are powder coated black or white. If the leak detector tube is not equipped with mechanical or electronic leak monitoring devices, to perform your weekly operating inspection, remove the cap and insert a clean dry wooden gauge stick into the leak detector tube until the wooden stick touches the bottom. Remove the gauge stick and visually inspect the gauge stick for any sign of fuel. If the gauge stick is wet or smells like hydrocarbon fuel, call your ConVault® distributor or the corporate office at 209-632-7571 or toll free **800-222-7099**. Be prepared to provide the following information:

1. Location of the tank
2. Tank size
3. UL or UL Canada serial number.

E. COMMUNICATION NIPPLE

ConVault® tanks are equipped with a one inch (1”) communication nipple powder coated red. Under normal operating conditions, the communication nipple should be kept capped. The communication port is provided to disperse air from the secondary containment during certain performance tests. Such tests, if deemed necessary by the ConVault® representative, should be performed under direct supervision of ConVault® or its authorized representative.

- **NOTE: If your ConVault® is fitted with a double walled steel tank, the 1” communication nipple is not required and therefore it will not be supplied.**

CAUTION **DO NOT** ever use the 2” Leak Detector Tube or the 1” communication nipple for filling the tank. These nipples are not connected to the primary tank. They are powder coated red to distinguish them from all other primary tank nipples, which are coated black or white. If the leak detector tube or the communication nipple are used as filling ports, or connected to any other filling or vapor recovery system, the secondary containment will be filled with fuel or petroleum product vapors. This will invalidate your ConVault® Limited Warranty. It is essential that all operating personnel and fuel delivery truck drivers are trained and are made familiar with the proper filling operations.



F. FUEL DISPENSING

- **Important Note:** Any pump described as “remote” must be approved by the Authorities Having Jurisdiction in advance of the installation of the pump. Specific operating instructions must be obtained from the manufacturer of such pump, and followed implicitly and exclusive of any Convault® directives.
- **NOTE:** The majority of Convault® tanks are equipped with either a Fill-Rite pump or GasBoy pump. However, your tank may have been supplied with a different pump make. Familiarize yourself with the make of the pump supplied with your tank. Make sure you get the manufacturer’s operating manual. Learn how to operate the pump, and make sure your operating personnel know how to operate it as well.
- **NOTE:** Do not overfill or top off fuel port.
- **NOTE:** The minimum 1/4” Styrofoam insulation and the six-inch (6”) concrete vault give thermal protection that minimizes temperature change for liquid fuels stored in excessively hot or cold environments. However, the liquid fuel will have some temperature variation at different times of the day. The liquid will expand or contract due to temperature changes and may slightly affect your level gauge indications. You may experience a slight variation in volume measurements for the same amount of liquid in the tank. On average, gasoline and diesel fuel will have about 0.6% and 0.4%, respectively, variation in volume for every 10-degree-F temperature difference. For example for a 6,000-gallon gasoline tank (full), a 10-degree-F temperature change will be equivalent to a 1/2” (or a 36 gallon) difference in liquid level in your tank.

G. OVERFILL PROTECTION

The U.S. EPA requires that the tank have overfill protection measures that include an overfill alarm and an automatic flow restrictor or flow shut-off. Additionally, all product transfers must be constantly monitored.

We recommend a level gauge or level indicator be installed on the tank to meet the fire code requirements. This gauge must be accessible to the delivery operator.

State or local fire or environmental regulations may contain additional requirements. Check with you local Authorities Having Jurisdiction.



NOTE: Check your tank and make sure which type of overfill protection you have received on your tank and familiarize yourself and your operating personnel with the accessories provided and their operation.

H. VENTING

1. Atmospheric Vent:

Convault® tanks must be provided with 2 inch vent line for venting into atmosphere in case of a pressure build-up inside the tank. Make sure vent cap is not obstructed to allow free flow of vapors from the vent. Obstruction of 2-inch vent line cap may lead to pressure build-up inside the tank and cause the emergency vent system to open.

2. Primary Tank Emergency Vent:

Convault® tanks must be provided with emergency pressure relief devices to automatically relieve the pressure of the primary tank before it reaches a maximum of 2.5 psig. Tank sizes from 125 gallon to 12,000 gallon are provided with 2 inch to 8-inch emergency pressure relief nipples and pressure relief devices. See WARNING under testing on page 60. Tanks with over 5,000 gallons capacity may have been provided with a manway cover that has long bolts instead of an emergency vent device. Before the pressure inside the tanks rises to 2.5 psig, the pressure relief device or the long bolt manhole cover rises, allowing the vapor inside the tank to escape and thus relieve the pressure inside the tank. At 2.5 psig pressure, the emergency venting device will be fully open.

3. Secondary Containment Emergency Vent:

The Convault® Non-Metallic secondary containment tanks have UL listing for emergency venting by "Form of Construction". Therefore, installation of an emergency vent on the secondary containment will not be required. If the Authorities Having Jurisdiction require the tank to be provided with an emergency vent, then the secondary containment may be provided with an emergency venting device as an optional item. Depending on the size of the tank the venting device size will be 4 inch to 8 inch. The emergency venting device will open before the secondary containment internal pressure reaches 2.5 psig. At 2.5 psig pressure, the emergency venting device will be fully open.

- **NOTE:** Familiarize yourself and your operating personnel with the emergency pressure relief systems provided and their operation on your tank. The Uniform Fire Code (UFC) requires the system to be fully operational at all times.



I. SPILL CONTAINMENT

ConVault® tanks are provided with 5 to 15-Gallon spill containment mounted on top of the tank, surrounding the tank fill-pipe with spill containment except for the remote fill. The containment will catch occasional spills. A hand-activated valve is provided inside the containment to drain the spill back into the primary tank.

J. BACTERIA MONITORING AND CONTROL

Bacterial infestation of fuel tanks and lines, originating from the fuel, chemically alter fuel to produce water, sludge and acids. Water and acids are corrosive and can cause severe corrosion in the tank, especially in the diesel fuel storage, at the bottom part of the tank in the interface between water and fuel. Also, microbial growth can cause fuel filter plugging, injection failing, system deposits, and corrosion of tanks and lines. You should arrange to have your fuel analyzed for microbial growth and to eradicate the infestation, if any. This program will prevent corrosion of your tank and piping and fuel filter plugging. Contact your fuel supplier for the locations and service of research labs that can test the fuel system and help you control bacterial infection. Also, ask your fuel supplier for the frequency of such tests needed to control bacterial infection. Bacteria cannot grow if there is no water in the fuel. Monitoring and controlling of water accumulation in the tank will also prevent bacterial growth. See paragraph K on water monitoring and control.

K. WATER MONITORING AND CONTROL

You may get water in the fuel through condensation of water vapor from the air. Water is heavier than fuel and therefore it settles at the bottom of the tank and causes corrosion. One way of minimizing condensation of water vapor inside the tank is by installing a pressure/vacuum vent (PVV) cap on your tank. The PVV cap normally keeps the vent line closed unless the internal tank pressure or vacuum opens it. The advantage of the PVV cap is that under normal operating conditions it keeps the outside air from entering the tank through the vent. Water may also enter the tank with the fuel delivered to you. You should regularly monitor the tank and make sure that there is no water accumulated at the tank bottom. If there is water at the tank bottom, you should pump it out with a small hand held pump called a "Thief Pump". If you do not monitor and pump out the water from the tank bottom, the useful life of your tank may be reduced dramatically.

CAUTION Water and bacteria monitoring and control are essential to preventing internal corrosion of steel tanks. Lack of such control measures by the owner and operator may invalidate the ConVault® Limited Warranty.

MAINTENANCE MANUAL

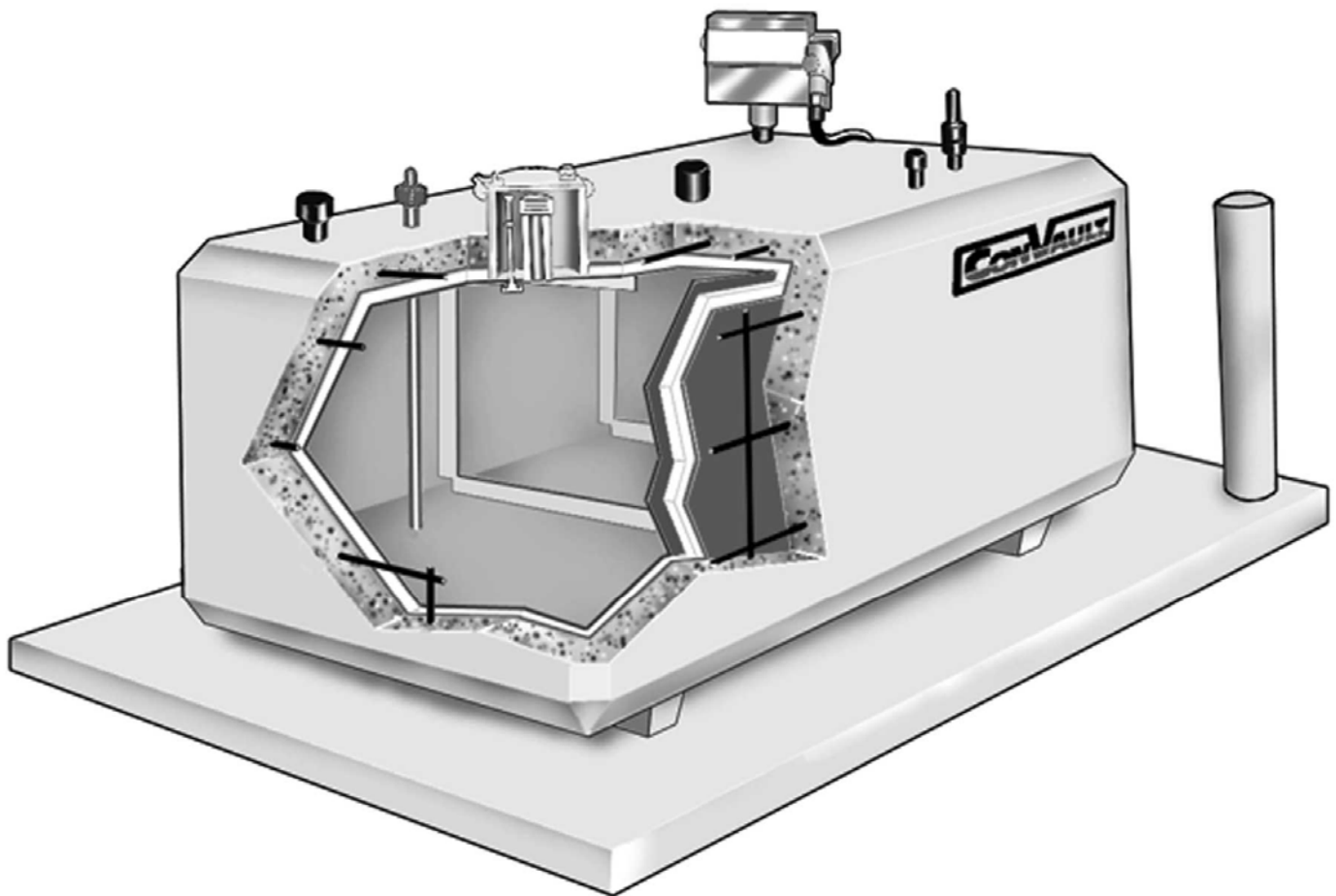



TABLE OF CONTENTS

	Page No.
A. FUEL TANK-CONVAULT®	52
B. FUEL PUMPS	53
C. NOZZLES	53
D. FILTER	53
E. MISCELLANEOUS VENTS, HOSES, AND GAUGES	54
F. EMERGENCY RELIEF VENT	54
G. LEAK DETECTOR PADLOCK	55
H. BACTERIA MONITORING AND CONTROL	55
I. WATER MONITORING AND CONTROL	55
J. PREVENTIVE MAINTENANCE	56



A. FUEL TANK-CONVAULT® (ALL SIZES)

▲WARNING Never enter a tank without proper equipment. Provide proper equipment and proper procedures for operation and maintenance personnel for entering a confined space. Entering a tank without proper equipment may result in injury or death.

▲WARNING There is potential for serious injury or death should someone access the top of the tank without appropriate ladders, stairs or fall protection. For ConVault tank models with heights above 4 feet, ladders, stairs, guardrails or equivalent fall protection systems must be used if a person accesses the top of the tank.

The owner/operator is required to inspect the tank visually on a regular basis, at least once a week. Visual inspection is the primary form of maintenance required. The inspection and maintenance should include the following:

1. Check for small cracks, and any signs of leakage. Fill and repair the small cracks. The touch-up paint provided at the time of delivery, for paint coated tanks, can be used for repair of the chipped paint.
2. Inspect all decals and signs and replace if not readable. Extra decals can be purchased through your local distributor. All decals must be on the tank before filling it.
- **NOTE:** Multi-Compartment tanks must be carefully labeled to prevent cross-filling the individual tanks; e.g., a D500 should be respectively labeled as diesel and gasoline to insure that each compartment can be easily identify by fuel truck driver or by the system operator.
3. Inspect the leak-detector tube for any signs of leakage from the primary steel tank into the secondary containment. **See specific instruction for leak detection under paragraph D, page 45 and paragraph G, page 55.**
4. Inspect nipples; spill containment and manholes for any sign of powder coating deterioration and corrosion. Remove the deteriorated and chipped off coating. Then sand, clean, and paint in accordance with the paint manufacturer's recommendation.
5. Confirm with your local fuel supplier the need to utilize additives for seasonal variances or to reduce corrosion of the inner steel tank due to local fuel impurities / intermittent moisture. Your local fuel supplier should be able to provide this guidance.

6. For Tank Maintenance Checklist, see Appendix A

B. FUEL PUMPS

- **IMPORTANT NOTE:** Any pump described as “remote” must be authorized by the Authorities Having Jurisdiction in advance of its installation. Pump manufacturer’s operating and maintenance instructions must be followed. The Convault® distributor can advise you how to contact the manufacturers for more details on fuel dispensing equipment and their maintenance procedures.

⚠ DANGER To avoid fire, electric shock, and injury or death, turn off power at circuit breaker or fuse. Test that power is off before servicing electrical wiring.

1. Follow pump manufacturer’s recommendation for the procedure and frequency of maintenance.
2. Disconnect electrical equipment from the main electric power to eliminate electrical shocks.
3. Check the motor for any sign of over-heating or excessive wear.
4. Check the meter and reset.
5. Have your electrical wiring connections checked by a qualified person.

C. NOZZLES

1. Visually inspect the nozzle for wear and tear.
2. Inspect the trigger mechanism for any sign of metal fatigue and mechanical failure.
3. Check for leaks around connection to hose.

D. FILTER

1. Replace the filter every six (6) months or as needed. Mark the date changed on the filter.
2. Check all fittings for leaks. Tighten or adjust the fittings as needed.



E. MISCELLANEOUS VENTS, HOSES, AND GAUGES

1. Visually inspect all vents, vent caps, hoses, level indicators and gauges at least once a week. Check hoses for leaks at least once a week.
 2. Check, all hoses and fittings for excessive wear--replace, if needed.
 3. Check fuel gauge for proper operation. Level indicator should indicate approximate amount of fuel in the tank. If gauge is not reading the proper amount of fuel, test fuel level manually with wooden stick gauge and compare it with automatic gauge. If gauge is not indicating the correct amount of fuel, remove and inspect the float assembly. If damaged, replace defective parts.
- **NOTE: The minimum 1/4" Styrofoam insulation and the six (6") concrete vault give thermal protection that minimize temperature change for liquid fuels stored in excessively hot or cold environments. However, the liquid fuel will have some temperature variation at different times of the day. The liquid will expand or contract due to temperature changes and may slightly affect your level gauge indications. You may experience a slight variation in volume measurements for the same amount of liquid in the tank. On average, gasoline and diesel fuel will have about 0.6% and 0.4% respectively, variation in volume for every 10-degree-F temperature difference. For example for a 6,000-gallon gasoline tank (full), a 10-degree-F temperature change will be equivalent to a 1/2" (or a 36 gallon) difference in liquid level in your tank.**

F. EMERGENCY RELIEF VENT

1. Check the operation of emergency relief vent of the primary tank (and the secondary containment venting device if provided) at least once a year by lifting top cap and releasing it. Emergency relief vent cap should operate free from any restrictions and reseal upon release. Emergency relief vent caps should not be propped open, as this action will facilitate loss of fuel through vaporization.
 2. Check atmospheric vent cap for proper operation and ensure that it is not obstructed or prevented from venting into atmosphere.
- **NOTE: Familiarize yourself with the emergency pressure relief system provided on your tank. The Uniform Fire Code (UFC) requires the system to be fully operational at all times. See paragraph H.2 on page 48 and WARNING on Page 60.**



G. LEAK DETECTOR PADLOCK

Inspect the lock on the leak detector tube cap for corrosion. Oil the lock in key slot with lightweight lube oil, when required. The lock should always be attached to the cap to prevent accidental filling of leak detector with fuel.

- **NOTICE:** See **CAUTION** under paragraph B, **FILLING THE TANK**, of **OPERATING MANUAL**, page 44 and paragraph D, **LEAK DETECTOR**, page 45.

H. BACTERIA MONITORING AND CONTROL

Bacterial infection on fuel tanks and lines, originating from the fuel, chemically alter fuel to produce water, sludge and acids. Water and acids are corrosive and can cause severe corrosion in the tank, especially in the diesel fuel storage and at the bottom part of the tank. Also, microbial growth can cause fuel filter plugging, injection failing, system deposits, and corrosion of tanks and lines. You should arrange to have your fuel analyzed for microbial growth and to eradicate the infestation, if any. This program will prevent corrosion of your tank and piping and fuel filter plugging. Contact your fuel supplier for the locations and service of research labs that can test the fuel system and help you control bacterial infection. Also, ask your fuel supplier for the frequency of such tests needed to control bacterial infection. Bacteria cannot grow if there is no water in the fuel. Monitoring and controlling of water accumulation in the tank will also prevent bacterial growth. See paragraph I on Water Monitoring and Control.

I. WATER MONITORING AND CONTROL

You may get water in the fuel through condensation of water vapor from the air. Water is heavier than fuel and therefore it settles at the bottom of the tank and causes corrosion. One way of minimizing condensation of water vapor inside the tank is by installing a pressure/vacuum vent (PVV) cap on your tank. The advantage of the PVV cap is that it normally keeps the vent line closed unless the internal tank pressure or vacuum opens it, thus reducing the amount of moist air entering the tank through the vent. You should regularly monitor the tank and make sure that there is no water accumulated at the tank bottom. If there is water at the tank bottom, you should pump it out with a small hand held pump called a "Thief Pump". If you do not monitor and pump out the water from the tank bottom, the useful life of your tank may be reduced dramatically.

CAUTION Water and bacteria monitoring and control are essential to preventing internal corrosion of steel tanks. Lack of such control measures by the owner and operator may invalidate the ConVault® Limited Warranty.



J. PREVENTIVE MAINTENANCE

1. Preventive maintenance can be less expensive compared to the cost of system shutdown and repairs. In the long run, preventive maintenance will save you money.
 2. See Appendix A for suggested Maintenance Checklist and Maintenance Procedures.
 3. Always be looking at how you can implement a preventive maintenance program.
- **FINAL NOTE: Should you require any assistance in the aforementioned maintenance instructions on Convault® aboveground fuel storage tanks, please call (800) 222-7099 for details or email us at info@convault.com.**

TESTING MANUAL

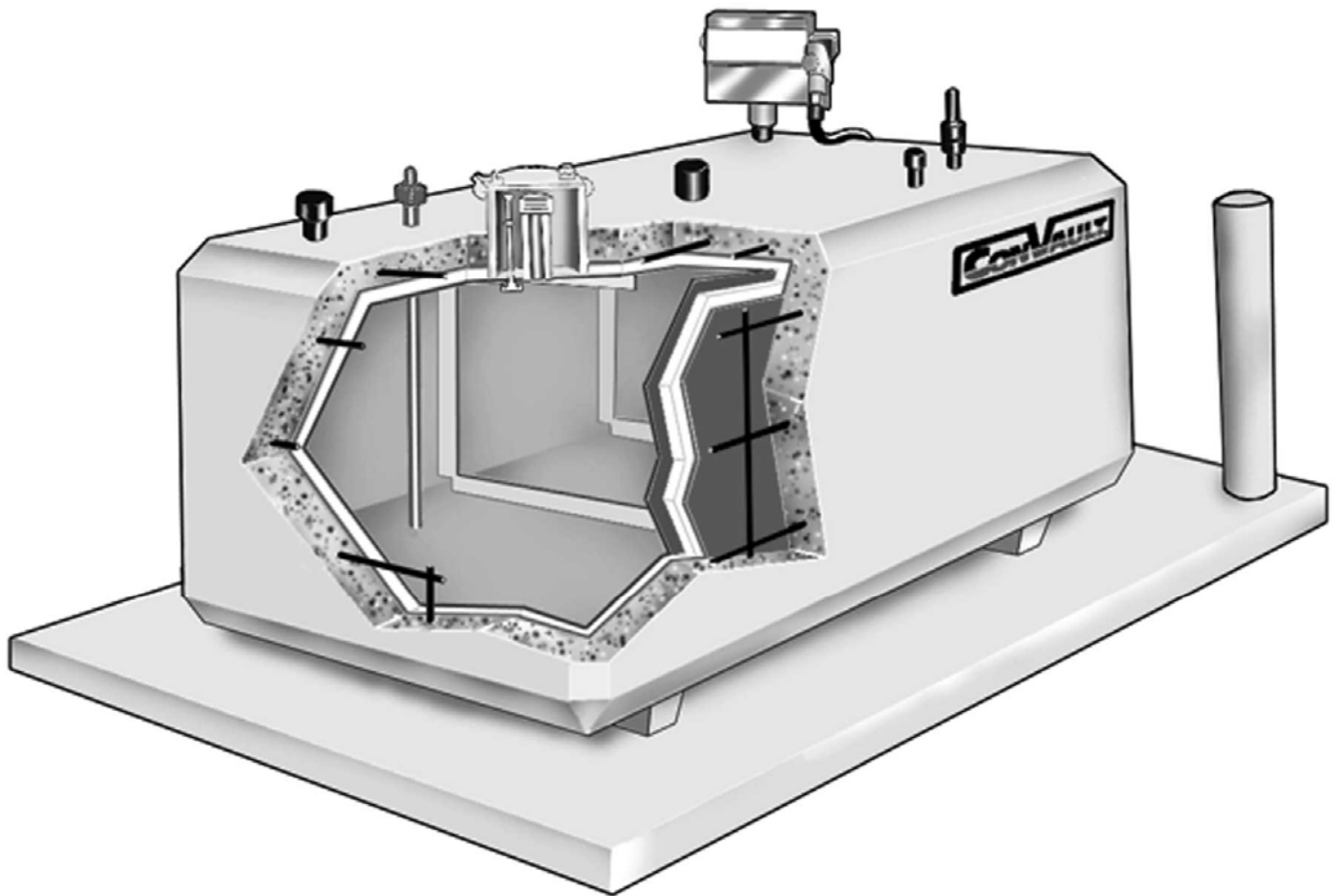



TABLE OF CONTENTS

	Page No.
A. GENERAL	59
B. AIR PRESSURE TEST PROCEDURES FOR PRIMARY STEEL TANK	59
C. TEST PIPING DIAGRAM (Figure 16)	61



A. GENERAL

Convault® tanks are shipped pre-assembled and shop-tested. However, if on-site testing is required proceed with the following instructions. Make sure every step of the test procedure is carried out according to the instructions and pay careful attention to the **Cautions** and **Warnings** in the procedure.

⚠ WARNING Using air, never pressure test a tank that contains flammable and combustible material. If the tank contains flammable or combustible material, it should be tested using inert gases such as Carbon Dioxide or Nitrogen. Improperly testing a tank containing flammable and combustible materials may cause an explosion in the tank resulting in death or serious injury.

B. AIR PRESSURE TEST PROCEDURE FOR PRIMARY STEEL TANK

Install test piping as shown in **Figure No. 16, page 61** and proceed as follows:

1. Temporarily plug, cap, or seal off remaining primary tank openings to hold the pressure.
2. If tank is equipped with a long-bolt manway for emergency venting, replace manway long-bolts with short-bolts and tighten them securely.
3. If the tank is equipped with standard emergency vent, remove the emergency vent and cap the opening to hold pressure as required.
4. If the tank is equipped with 1-inch communication nipple, remove the cap from the communication nipple for the secondary containment.
5. If the tank is not equipped with a communication nipple, remove or open the cap on the leak detector tube.
6. If leak detector tube is equipped with mechanical or electronic level detection equipment, remove the equipment to allow the air to freely escape from the annular space.

⚠ CAUTION The test air supply should not be more than 3 psig. Use only calibrated diaphragm type air pressure gauges with a zero to 10-psig dial span. Set pressure relief valve in test air supply line at 3 psig. Over pressurization of a tank may burst the tank and cause injury.

7. Close valve A.

8. Connect regulated test air supply line to test piping as shown in **Figure No. 16** for single compartment tank. If the tank contains more than one primary compartment tank, use the same piping arrangement for each compartment and pressure test them all. The vault may contain up to 4 primary tank compartments.

CAUTION Verify that the test air supply line pressure regulator is properly set at 3 psig before proceeding.

9. Slowly open valve A to pressurize the primary tank. Close valve B. Pressure gauge should indicate a pressure of 3 psig.

CAUTION Never leave a pressurized tank unattended. The air inside the tank may heat up and gently cause the pressure inside the tank to rise above 3-psig maximum pressure. If pressure in the tank rises, the pressure should be reduced to 3 psig by opening the valve B. Failure to constantly monitor the tank internal pressure may damage the tank.

10. Close valve A. Disconnect test air supply line from test piping.
11. Hold test pressure in primary tank for 1-hour minimum. A steady drop in pressure gauge reading indicates that there may be a leak in the plumbing or in the primary tank. Make sure that plumbing is airtight.
12. If no leaks are found and the tank passes the test, then open valve A and B and let the air out of the primary tank.
13. With tank de-pressurized, remove test piping, temporary plugs, caps and seals. Reinstall the cap on the communication nipple or the level indication equipment on the leak detector tube. Reinstall emergency relief vents. If tank is equipped with an emergency vent long-bolt manway, reassemble manway cover with bolts supplied by tank manufacturer.

WARNING Reassemble manway cover with proper size and type of long-bolt, with a minimum unthreaded length of 2 inches, so that when cover is fully raised, there is a 1-1/2 inch minimum space between manway cover and frame. Failure to properly assemble cover of a long-bolt manway used for emergency venting may make vent inoperable causing bodily injury or damage to the tank.

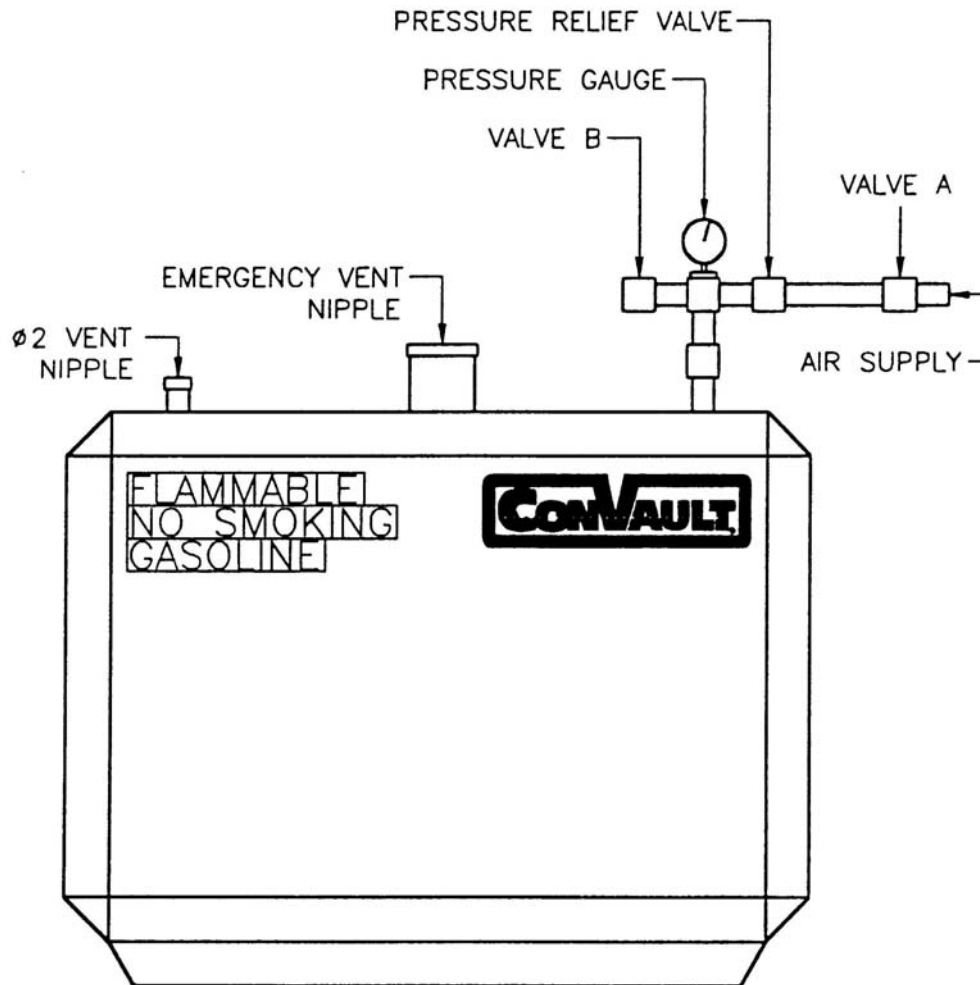
C. Test Piping Diagram**Figure No. 16****NOTE:**

PLUG, CAP OR SEAL OFF ALL PRIMARY TANK OPENINGS.

APPENDIX A & B

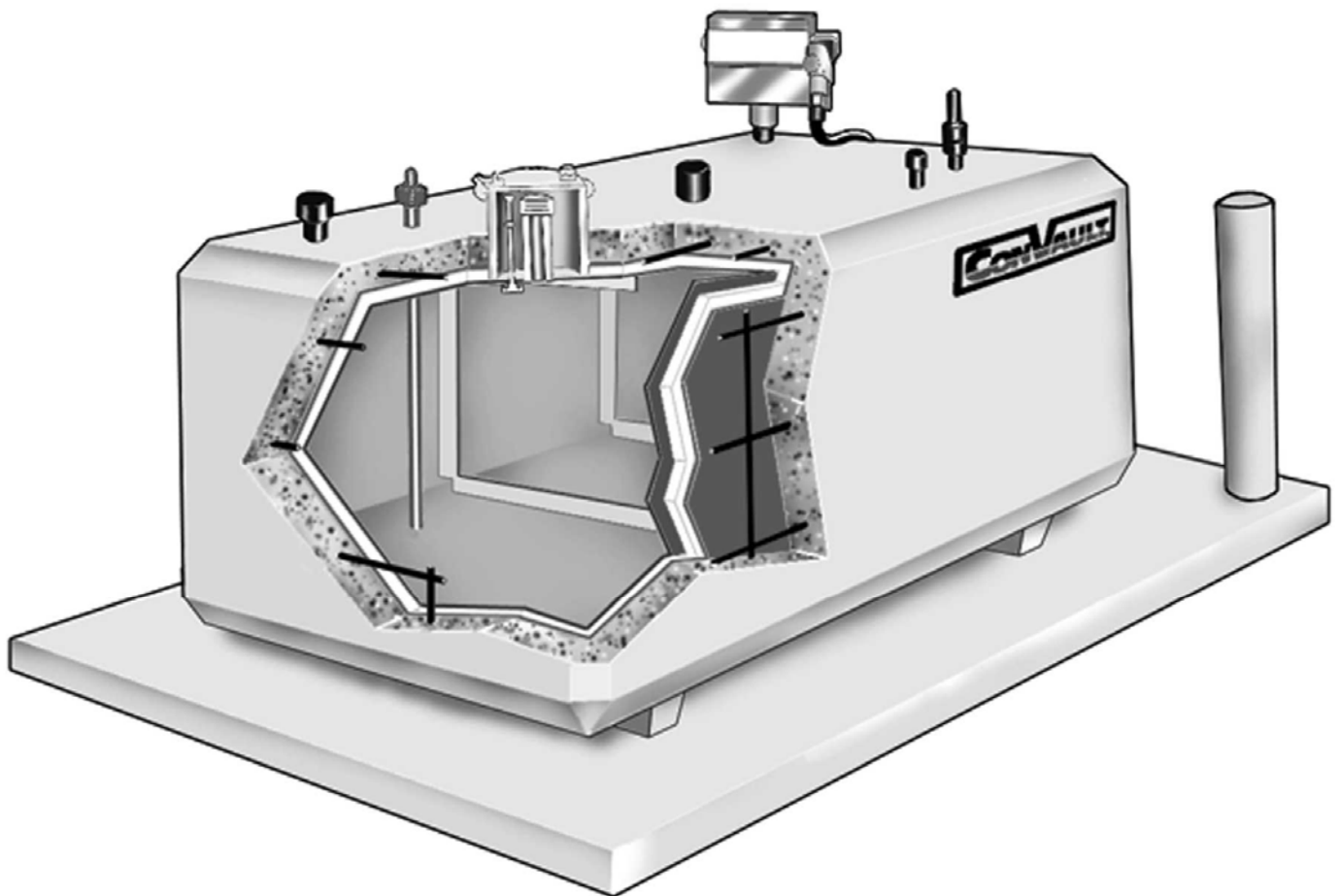



Maintenance Checklist

Inspection Date _____

Inspector _____

Note: This checklist is designed for general use. Some items may not apply. All equipment inspections and maintenance should be documented. You are **encouraged** to make copies of this checklist. See the corresponding maintenance procedures and your owner's manual for corrective actions and more details.

Weekly Maintenance:

- 1. Check leak detector for indication of fluid in interstice. (This is required by warranty.) If checked with a stick gauge, ensure the stick is clean and dry before insertion.
- 2. Check for leaks on the pumps, filters, hoses, nozzles, joints and fittings.
- 3. Check nipples, spill containment and manholes for paint or powder coating decay (required by warranty) and that all openings are properly sealed. Check piping and fittings for rust.
- 4. Check pump meter and reset button.
- 5. Check fuel gauge for proper operation. If you have a Kruger At-A-Glance Gauge, check the clear cap for weathering or cracks.
- 6. Check spill containment for debris.
- 7. Check for small cracks in concrete.
- 8. Check readability of signs and decals.

Monthly Maintenance:

- 9. Check for water in the primary tank bottom under the fuel (required by warranty).
- 10. Visually check the tank, including under the tank for any signs of leakage as required by the Environmental Protection Agency 40 CFR 112.
- 11. Check leak detector tube cap for corrosion and proper operation. If a Kruger manual leak indicator is installed, remove the red ring and clear cap and check to see that the red indicator moves up and down about 1 inch freely. Also, check for weathering or cracks in the clear cap. If electronic leak detection is installed, check it by using the test button.
- 12. Check all nozzles, hoses and fittings for wear and tear.
- 13. Check trigger mechanism on nozzle for metal fatigue or mechanical failure.
- 14. Check pump motor for signs of over-heating or excessive wear.
- 15. Check body of tank for cleanliness, need of paint, or rusting where applicable. Check signs and decals for need of replacement. Check slab and supports of unit for structural soundness.
- 16. Visually check grounding wires to see that they are properly attached to the tank terminals and grounding rod.

Other Periodic Maintenance:

- 17. Replace the dispenser filter at least every six (6) months or as needed (mark the date replaced on the filter).
- 18. Check fuel for bacterial infestation or microbial growth.
- 19. Have a qualified person check all electrical wiring at least annually.
- 20. Annually check that the normal vent is free of obstructions.
- 21. Check the emergency relief vent at least once a year by lifting the top cap and releasing it to ensure freedom of movement.
- 22. At least once a year check over-fill prevention valve and high-level alarm for proper operation.
- 23. At least once a year, remove the leak detection device and check for proper operation.
- 24. At least once a year, check the calibration of the fuel gauge.
- 25. Follow the pump manufacturer's recommendation for frequency and procedures of maintenance.
- 26. Document significant storage events per 40 CFR 112 and your state regulations.



Maintenance Procedures

Please note that item numbers on this sheet correspond to the item numbers on the Maintenance Checklist. Most of the maintenance requirements and procedures are also covered in the Convault® owner's manual.

Weekly Checks:

1. If leak detector indicates fluid in the interstice, remove any devices and determine what the fluid is. Call your Convault® representative.
2. If fuel leaks are detected, contact the appropriate authorities as necessary. Tighten, repair as necessary, replace components, or contact your installer or service company.
3. If paint or powder coating deterioration occurs on nipples, spill containment or manholes, clean to bare metal, prime with a good quality zinc based primer, and repaint. If corrosion is severe, contact your Convault® representative as soon as practical. Cap any unsealed nipples.
4. If dispenser meter is not working or will not reset, call your service company or installer.
5. If the fuel gauge fails to operate properly, repair/replace it, or call your service company before the next delivery. (It is the owner/operator's responsibility to prevent the overfilling of the tanks. The gauge is part of the required system to prevent overfilling.) If the Kruger gauge cap has deteriorated, it could be allowing rainwater into the primary tank and should be replaced.
6. Keep spill containment clear of debris at all times. A contaminated spill containment will cause the fuel to be contaminated when any spill is released through the drain into the primary tank. Materials such as rags or paper products used to clean the spill containment must be disposed of properly, as they will usually contain fuel from the spill containment.
7. If there are small cracks in the concrete, fill and repair them. If you have questions, call your local Convault® representative.
8. If signs or decals lose visibility, order replacements from your local Convault® representative before the next time the tank is filled.

Monthly:

9. If there is water in the tank it will collect at the bottom, under the fuel. Water in the tank will cause increased corrosion. If you discover water in the primary tank it must be removed. One method is to pump it out with a "Thief Pump", a small pump that pulls the water from the bottom 1/8" of the tank. Check tank openings for possible water entry points. If you find that you are pumping out more than one half gallon of water for every 1000 gallons of product stored, see your fuel dealer, or call your Convault® representative. Also consult paragraph I in the maintenance section of the owner's manual.
10. If you detect leakage, determine what the liquid is, if possible. If it is fuel, call your Convault® representative and appropriate authorities as necessary. If it is water, seal the top using the Convault® repaint guidelines.
11. If there are problems with the leak detector tube or lock, clean and lubricate them as necessary. See paragraph G in the maintenance section of the owner's manual. If the Kruger leak indicator does not function properly, remove it and repair or replace it. Due to ultraviolet radiation, the clear cap on the Kruger leak indicator will deteriorate over time. If it has deteriorated, it could be allowing rainwater into the interstitial area and should be replaced. New caps and rings or entire units can be purchased from Kruger, your service company, or your Convault® representative. Kruger now offers a guard, which will prolong the life of the cap. If electronic leak detection test fails, call your service company.



12. If nozzles, hoses or fittings exhibit signs of wear and tear, repair/replace as necessary or call your service company.
13. If trigger mechanism on nozzle exhibits signs of metal fatigue or mechanical failure, replace nozzle or call your service company.
14. If pump motor shows signs of overheating such as housing discoloration or excessive wear such as bearing noise, repair as necessary or contact your service company.
15. Clean, paint, and repair problem areas as necessary. Order replacements signs or decals from your local Convault® representative. If the slab is cracking or settling, contact your local Convault® representative and your slab installer. If you have questions, call your local Convault® representative.
16. Make a visual inspection of grounding wires. If they are not attached properly, make appropriate changes or call your installer or your service company.

Other Periodic Maintenance:

17. Filters can be purchased from your Convault® representative or local service company. Write on the filter the date replaced using a permanent marker, or scratch it on with a sharp object.
18. If bacterial infestation is detected, consult paragraph H in the maintenance section of the owner's manual.
19. Repair as necessary. Wiring (other than intrinsically safe items) in a class 1 area requires special sealing to prevent explosions.
20. Visually check that the venting has not been obstructed, and remove or clear any obstructions.
21. If the emergency relief vent exhibits signs of motion restriction, promptly call your installer, your service company, or your Convault® representative. Proper operation of this device is critical as most injuries and fatalities that happen in conjunction with fuel fires are due to improper, non-functional emergency relief vents or emergency relief vents replaced with normal pipe caps.
22. Most fill-limiting and high-level alarm devices use a float. By removing the device you can easily check for movement of the float and proper mechanical or electronic operation. If the device fails to operate properly, call your installer or your service company.
23. Most leak detection devices use a float. By removing the device from the leak detector tube and turning it upside down (simulating a floating situation) you can easily check for movement of the float and proper mechanical or electronic indication. If the leak detection device fails to operate properly, call your installer or your service company.
24. The fuel gauge can be checked by "sticking" the tank and comparing it to the gauge reading. Some gauges are more accurate than the stick. If the gauge reading varies substantially from the stick reading, contact the gauge manufacturer or your service company. If your stick reads in inches only and you need a calibration/conversion chart, contact your Convault® representative or download a copy from the Convault® website.
25. Pump maintenance requirements vary by manufacturer. If you have questions, contact your installer, local service company, or the manufacturer of the equipment.
26. If you have a warranty or environmental problem down the road, documentation will be very helpful. We recommend that you keep a copy of the "Maintenance Checklist" with items marked for every maintenance inspection. Notes about problems and corrections can be written on the back of the sheet and used for future reference. Many sites are now required to have a SPCC plan for emergencies on file. If you need a recommendation for companies that do this, please call your Convault® representative. **The name, phone number and location of your local representative can be obtained from the ConVault® web site by clicking on "Local Distributor" and your state or country at <http://www.convault.com>.**



LIGHTNING PROTECTION INSTALLATION INSTRUCTIONS

A. Introduction

Convault® tanks should be grounded to provide lightning protection in accordance with NFPA 780 Standard for the Installation of Lightning Protection Systems latest edition. Each Convault® tank is provided with two grounding lugs or grounding bolts to meet the lightning protection requirements of Section 6-4.1 of NFPA 780 for “Aboveground Tanks at Atmospheric Pressure Containing Flammable Vapors or Liquids that Can Give Off Flammable Vapors”.

B. Priority of Codes, Rules and Regulations

Use the following list as your order of priority:

1. Local jurisdiction codes, rules and regulations,
2. Applicable state codes, rules, and regulations,
3. Applicable regional and national codes, rules and regulations,
4. Component manufacturer’s recommended installation, maintenance and operating procedure,
5. These Convault® Installation Instructions for Lightning Protection.

C. Conductor Cable Materials Specifications

Conductor cable material, cross sectional area, size of each strand and weight per length shall be in accordance with Section 3-1 & 3-2 and table 3-1.1 (a) and 3-1.1(b) of NFPA 780.

D. Ground Rods

Ground rods shall be not less than ½ in. (12.7 mm) in diameter and 8 ft (2.4 m) long. Grounding rod materials specification and installation shall be in accordance with section 3-13 Ground Terminal of NFPA 780.

E. Ground Rod Termination

The down conductor shall be attached to the ground rod by bolting, brazing, welding or using high-compression connectors listed for the purpose. Clamps shall be suitable for direct soil burial. Lightning installation shall be in accordance with section 3-13.1.1 through 3-13.1.5 and figures 3-13.1.2, 3 and 5 of NFPA 780.



4109 E. Zeering Road, Denair, CA 95316

1-800-222-7099

1-209-632-7571

Fax 1-209-632-4711

info@convault.com

<http://www.convault.com>